

# Amphenol Docking Connectors

Amphenol Aerospace offers the ideal connector for applications where frequent docking to charge and transfer data is a necessity. Utilizing Amphenol's Brush contact system, this connector system offers high performance of over 100,000 mating cycles.

## Brush Technology



### Brush Technology

Strands of high tensile strength wire are bundled together to form brush-like contacts. By intermeshing two wire bundles together, an electrical connection is made.

#### Brush Attributes:

- Low Mating Force: 70-90% less than conventional pin and socket
- Provides multiple points of contact, 14-70 points of contact per mate.
- Impervious to fretting corrosion
- Long contact life, over 100,000 mating cycles without degradation in performance.

Amphenol's docking connectors are designed for applications of:

- Handheld GPS Units
- Handheld Radios
- Rugged Computers
- Controllers
- Scanners
- Accessories
- Cellular Phone



### Amphenol Design Engineering and Manufacturing Expertise

We take pride that Amphenol Aerospace is the undisputed leader in interconnect systems for aerospace/harsh environment applications. Such applications require a high degree of engineering sophistication and precision manufacturing capabilities that only a company that has been in the interconnect product design and manufacturing business for over 50 years can offer.

Expert design and applications engineering provides solid modeling and full Pro-E capabilities to develop new interconnect products and perform structural analysis. In addition, Amphenol's team of dedicated signal integrity engineers characterize our interconnect products and optimize for high speed.



# Performance

Durability:	Up to 100,000 mating cycles
Insertion/Extraction Force:	1.5 ounce typical per contact
Operating Temperature:	-65° to 125°C
Current Rating:	Up to 5 amperes (termination dependent) Hot swap 1 ampere maximum (load dependent)
Data Rate: (Select connectors only)	Configurable for 3.125 Gbps differential signal
Insulation Resistance:	5 gigaohms minimum
Dielectric Withstanding Voltage:	750 volts @ Sea Level Minimum 250 volts @ 70,000 Feet Elevation Minimum
Solderability:	MIL-STD-202, Method 208
Salt Fog:	48 Hours IAW MIL-STD-1344, method 1001, test condition B
Humidity:	IAW MIL-STD-1344, method 1002, type II
Vibration:	4 hours in each of 3 mutually perpendicular axes IAW MIL-STD-1344, method 2005, test condition V, letter H
Shock:	1 shock along each of three mutually perpendicular axes IAW MIL-STD-1344, method 2004, test condition G

# Features

Radial Misalignment:	Capable of correcting up to a .040" initial radial misalignment
Angular Misalignment:	Capable of mating with up to a 4° initial angular misalignment
Polarization:	"D" shaped interface
Color:	Standard – Black plus a wide variety of colors available

# Materials

Insulator:	Glass filled thermoplastic molding
Contact:	Wire: Beryllium copper per ASTM B197; finish is gold per ASTM B488 over nickel per AMS-QQ-N-290.  Holder: Brass similar to UNS C33500; finish is gold per MIL-G-45204 or tin-lead per MIL-P-81728 or tin per MIL-T-10727 (RoHS Compliant).  Sleeve: Stainless Steel per AMS-5514, passivated IAW QQ-P-35 (DB and I/O connectors only)

### Custom Contacts

.0787 X .100 Staggered Grid Spacing

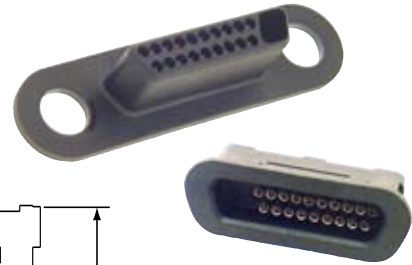
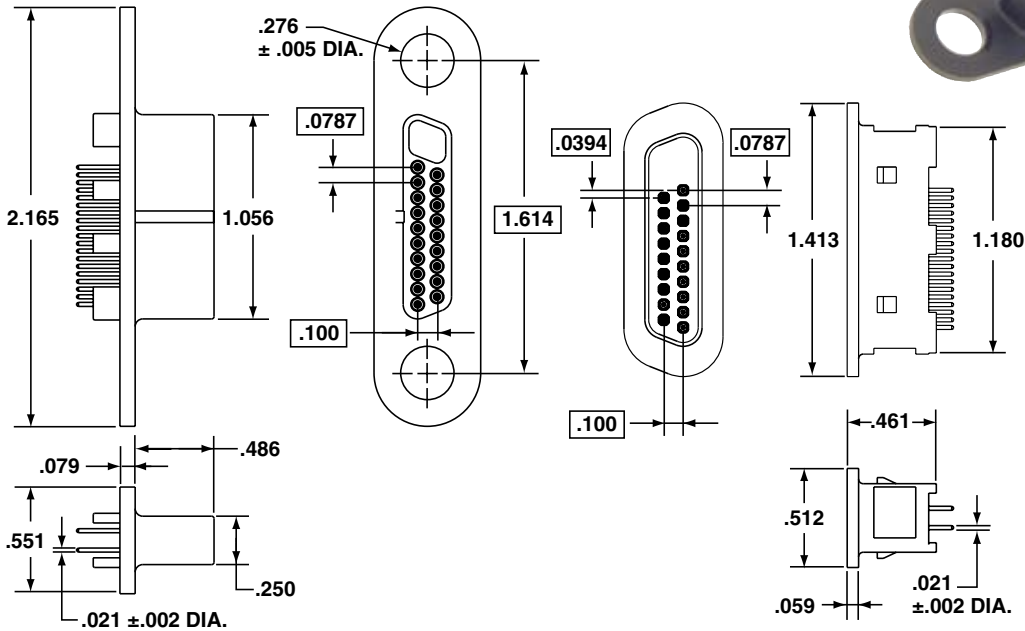

### High Density Brush (HDB<sup>3</sup>) Connector Series

.070 X .060 Staggered Grid Spacing

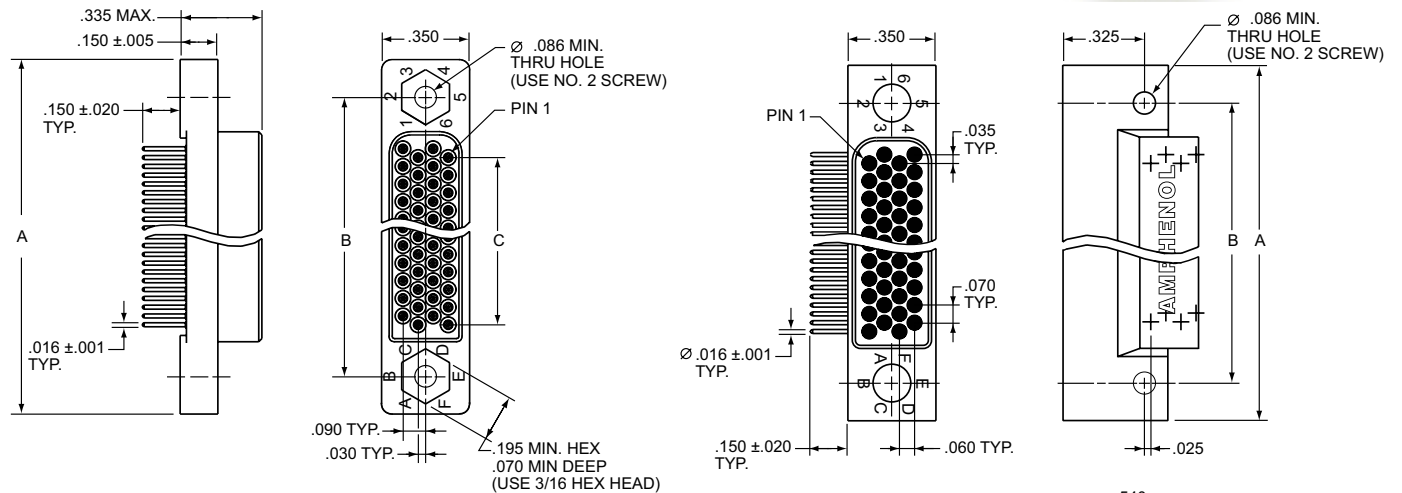

Dimensions			
Number of Contacts	A	B	C
20	1.025	.725	.280
40	1.375	1.075	0.630

See Amphenol HDB3 Data sheet, PDS-201, for additional contact arrangements



### Low Mating Force Rectangular Connector Series

.100 X .100 Square Grid Arrangement

(Reference MIL-55302/166 thru /170)

Mother Board Connector

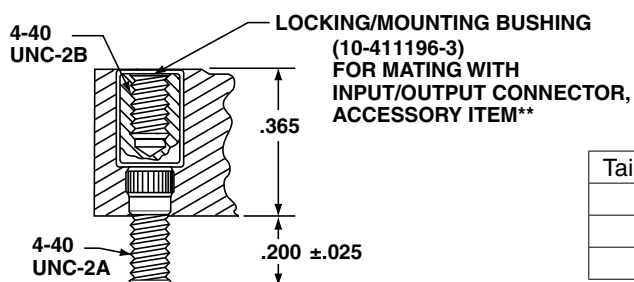
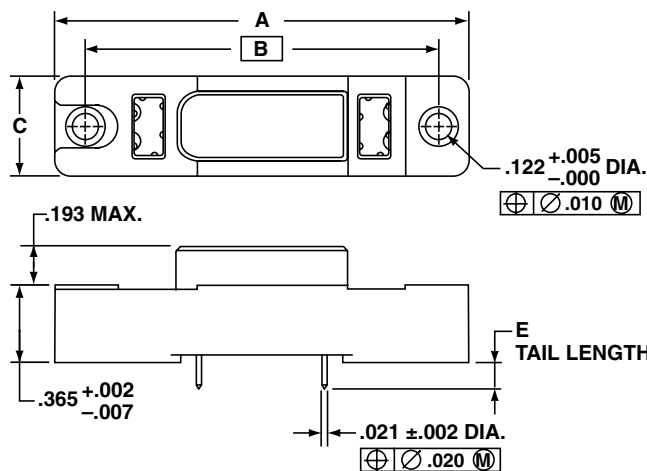

Tail Length E ± .020
.148
.180
.335

Number of Contacts	Contact Pattern	A Max	B	C Max
10	2 X 5	1.795	1.475	.390
12	2 X 6	1.895	1.575	.390
14	2 X 7	1.995	1.675	.390
15	3 X 5	1.795	1.475	.490
16	2 X 8	2.095	1.775	.390
18	2 X 9	2.195	1.875	.390
	3 X 6	1.895	1.575	.490
20	4 X 5	1.795	1.475	.590
21	3 X 7	1.995	1.675	.490
24	3 X 8	2.095	1.775	.490
	4 X 6	1.895	1.575	.590
27	3 X 9	2.195	1.875	.490
28	4 X 7	1.995	1.675	.590
32	4 X 8	2.095	1.775	.590
36	4 X 9	2.195	1.875	.590

See Amphenol Low Mating Force Rectangular Catalog, 12-035, for additional contact arrangements

### Daughter Board Connector

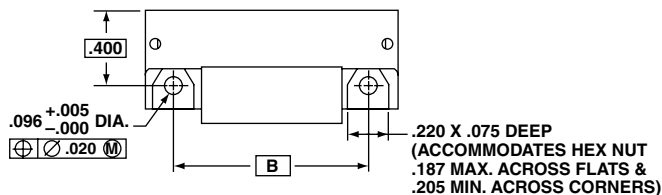
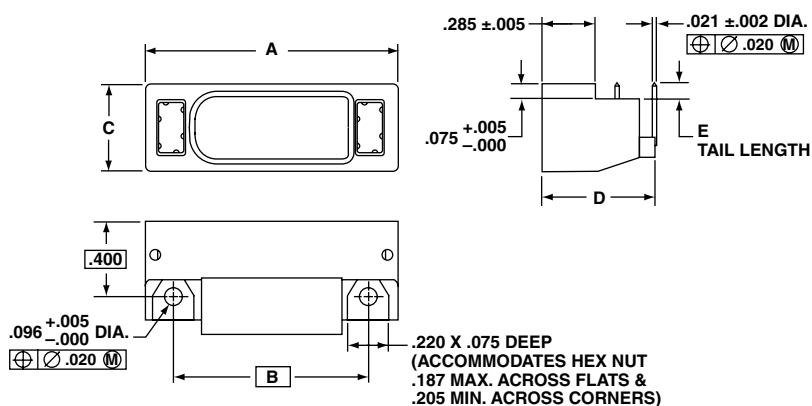

Tail Length E ± .020
.085
.120
.300

Number of Contacts	Contact Pattern	A Max	B	C Max	D Max
10	2 X 5	1.180	.850	.375	.545
12	2 X 6	1.280	.950	.375	.545
14	2 X 7	1.380	1.050	.375	.545
15	3 X 5	1.180	.850	.475	.645
16	2 X 8	1.480	1.150	.375	.545
18	2 X 9	1.580	1.250	.375	.545
	3 X 6	1.280	.950	.475	.645
20	4 X 5	1.180	.850	.575	.745
21	3 X 7	1.380	1.050	.475	.645
24	3 X 8	1.480	1.150	.475	.645
	4 X 6	1.280	.950	.575	.745
27	3 X 9	1.580	1.250	.475	.645
28	4 X 7	1.380	1.050	.575	.745
32	4 X 8	1.480	1.150	.575	.745
36	4 X 9	1.580	1.250	.575	.745

See Amphenol Low Mating Force Rectangular Catalog, 12-035, for additional contact arrangements

### Input/Output Connector

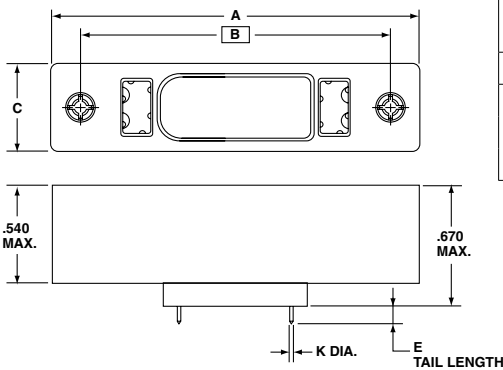

Contact Type	Diameter K ± .002	Length E ± .020
Crimp Contact	N/A	N/A
Round PCB Stud Solder Termination	.021	.060
	.021	.145
	.021	.335

Number of Contacts	Contact Pattern	A Max	B	C Max
10	2 X 5	1.795	1.475	.390
12	2 X 6	1.895	1.575	.390
14	2 X 7	1.995	1.675	.390
15	3 X 5	1.795	1.475	.490
16	2 X 8	2.095	1.775	.390
18	2 X 9	2.195	1.875	.390
	3 X 6	1.895	1.575	.490
20	4 X 5	1.795	1.475	.590
21	3 X 7	1.995	1.675	.490
24	3 X 8	2.095	1.775	.490
	4 X 6	1.895	1.575	.590
27	3 X 9	2.195	1.875	.490
28	4 X 7	1.995	1.675	.590
32	4 X 8	2.095	1.775	.590
36	4 X 9	2.195	1.875	.590

See Amphenol Low Mating Force Rectangular Catalog, 12-035, for additional contact arrangements

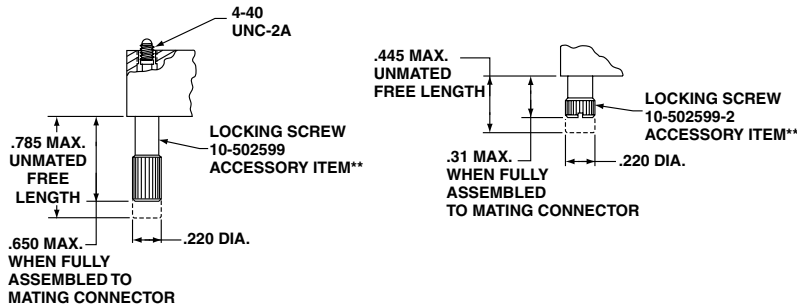

### Printed Circuit Connector

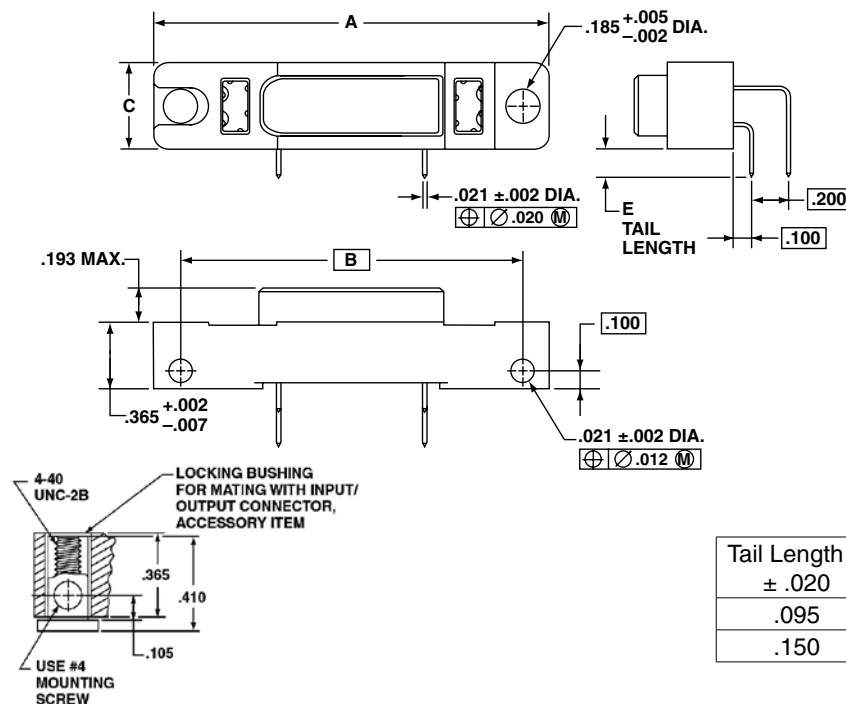

Number of Contacts	Contact Pattern	A Max	B	C Max
10	2 X 5	1.795	1.475	.390
12	2 X 6	1.895	1.575	.390
14	2 X 7	1.995	1.675	.390
15	3 X 5	1.795	1.475	.490
16	2 X 8	2.095	1.775	.390
18	2 X 9	2.195	1.875	.390
	3 X 6	1.895	1.575	.490
20	4 X 5	1.795	1.475	.590
21	3 X 7	1.995	1.675	.490
24	3 X 8	2.095	1.775	.490
	4 X 6	1.895	1.575	.590
27	3 X 9	2.195	1.875	.490
28	4 X 7	1.995	1.675	.590
32	4 X 8	2.095	1.775	.590
36	4 X 9	2.195	1.875	.590

Tail Length E ± .020
.095
.150

See Amphenol Low Mating Force Rectangular Catalog, 12-035, for additional contact arrangements

Notice: Specifications are subject to change without notice. Contact your nearest Amphenol Corporation Sales Office for the latest specifications. All statements, information and data given herein are believed to be accurate and reliable but are presented without guarantee, warranty, or responsibility of any kind, expressed or implied. Statements or suggestions concerning possible use of our products are made without representation or warranty that any such use is free of patent infringement and are not recommendations to infringe any patent. The user should assume that all safety measures are indicated or that other measures may not be required. Specifications are typical and may not apply to all connectors.



AMPHENOL is a registered trademark of Amphenol Corporation.

©2008 Amphenol Corporation Printed in U.S.A. 1/21/2008

Call 800-678-0141 or visit us at [www.amphenol-aerospace.com](http://www.amphenol-aerospace.com)