

**CONNECTOR
 DESIGNATORS
 A-F-H-L-S
 ROTATABLE
 COUPLING**

**TYPE D INDIVIDUAL
 OR OVERALL
 SHIELD TERMINATION**

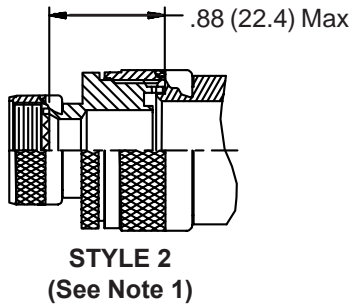
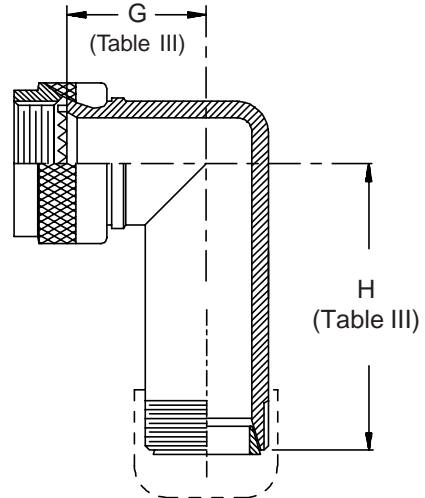
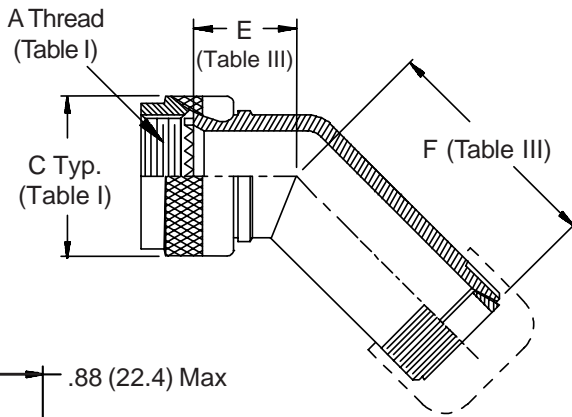
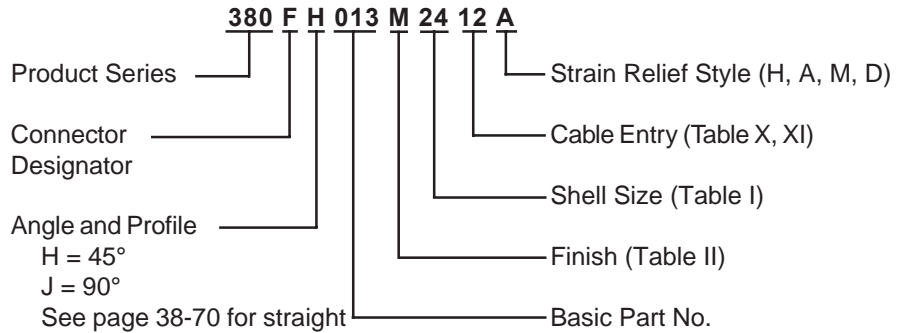

-445 Now Available with the "NESTOR"

Glenair's Non-Detent, Spring-Loaded, Self-Locking Coupling.
 Add "-445" to Specify This AS85049 Style "N" Coupling Interface.

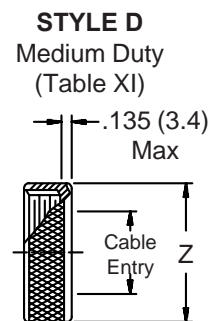
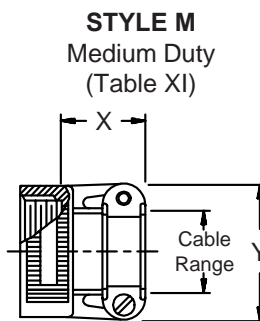
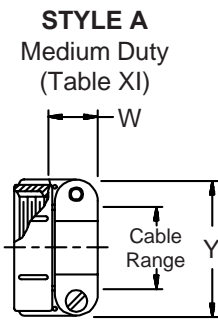
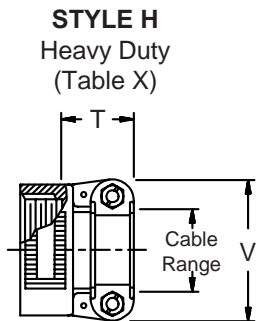

**CONNECTOR
DESIGNATORS
A-F-H-L-S
ROTATABLE
COUPLING**

**TYPE D INDIVIDUAL
OR OVERALL
SHIELD TERMINATION**

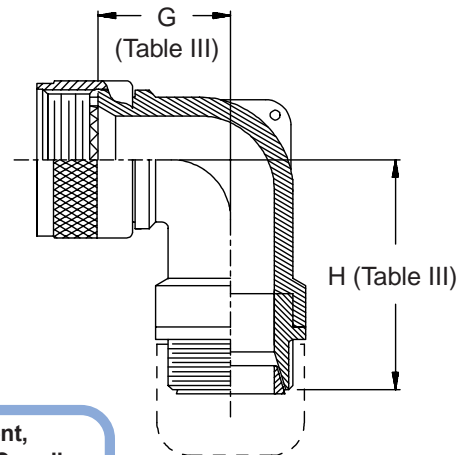
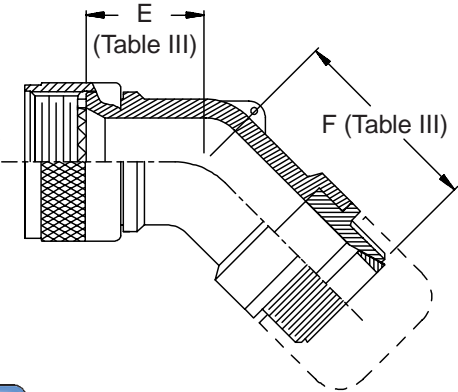
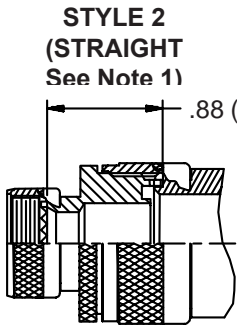
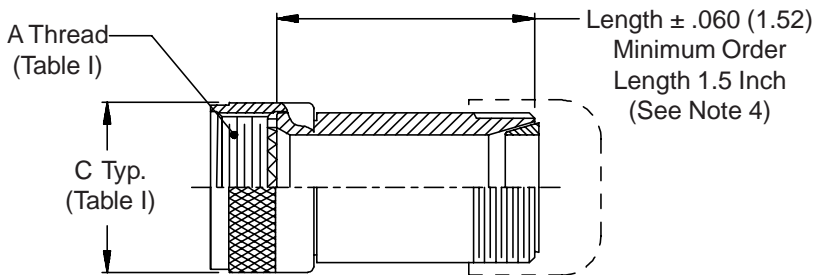
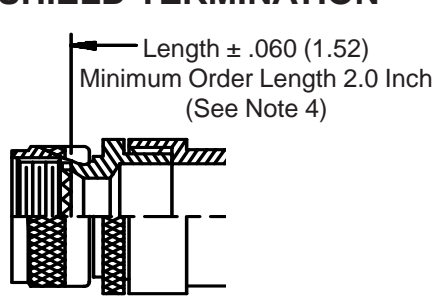
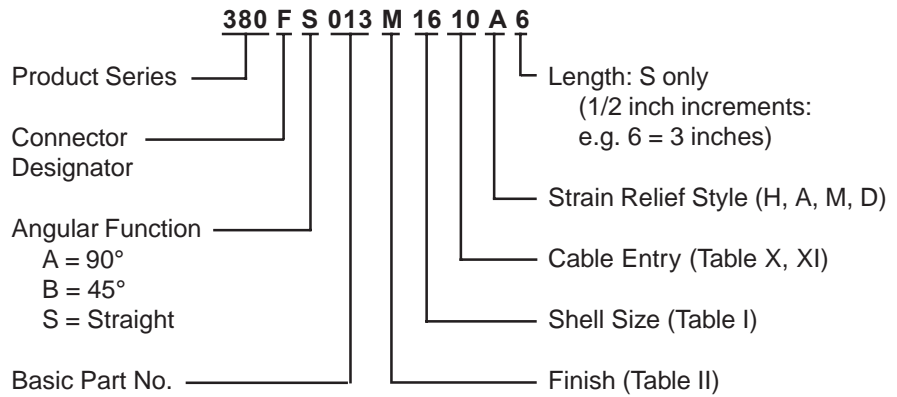

**STYLE 2
(45° & 90°
See Note 1)**

-445 Add "-445" to Specify Glenair's Non-Detent, ("NESTOR") Spring-Loaded, Self-Locking Coupling. See Page 41 for Details.

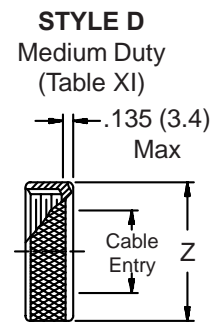
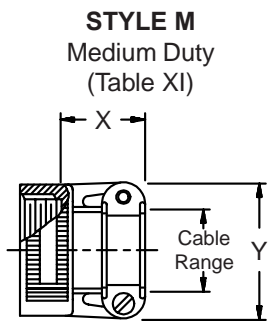
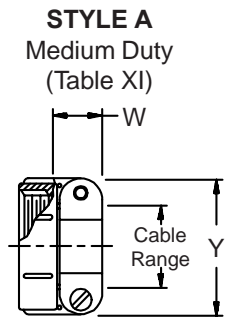
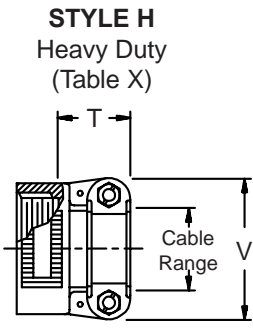

380-013
EMI/RFI Non-Environmental Backshell
with Strain Relief
Type D - Rotatable Coupling - Low Profile



TABLE III: ELBOW DIMENSIONS

Shell Size		E		F		G		H	
Conn. Desig.	H	Max		Max		Max		Max	
A-F-L-S									
08	09	.457	(11.6)	1.730	(43.9)	.560	(14.2)	1.680	(42.7)
10	11	.520	(13.2)	1.730	(43.9)	.660	(16.8)	1.800	(45.7)
12	13	.582	(14.8)	1.790	(45.5)	.670	(17.0)	1.820	(46.2)
14	15	.645	(16.4)	1.880	(47.8)	.760	(19.3)	1.890	(48.0)
16	17	.738	(18.7)	1.990	(50.5)	.950	(24.1)	1.980	(50.3)
18	19	.926	(23.5)	2.180	(55.4)	1.030	(26.2)	2.150	(54.6)
20	21	.926	(23.5)	2.180	(55.4)	1.030	(26.2)	2.150	(54.6)
22	23	1.020	(25.9)	2.330	(59.2)	1.180	(30.0)	2.260	(57.4)
24	25	1.020	(25.9)	2.330	(59.2)	1.180	(30.0)	2.260	(57.4)
28		1.145	(29.1)	2.380	(60.5)	1.280	(32.5)	2.430	(61.7)
32		1.207	(30.7)	2.480	(63.0)	1.630	(41.4)	2.680	(68.1)
36		1.238	(31.4)	2.570	(65.3)	1.830	(46.5)	2.680	(68.1)

See inside back cover
 fold-out or pages 13 and
 14 for unabridged
 Tables I and II.

TABLE II: STANDARD FINISHES

GLENAIR SYMBOL	FINISH
B	Cadmium Plate, Olive Drab
M	Electroless Nickel
NF	Cadmium Plate, Olive Drab Over Electroless Nickel

See Inside Back Cover
for Additional Finish Options

TABLE X: CABLE ENTRY

Dash No.	T Max	V Max	Cable Range	
			Min	Max
04	.780 (19.8)	.957 (24.3)	.125 (3.2)	.312 (7.9)
06	.780 (19.8)	1.145 (29.1)	.250 (6.4)	.437 (11.1)
08	.780 (19.8)	1.332 (33.8)	.312 (7.9)	.562 (14.3)
10	.780 (19.8)	1.332 (33.8)	.350 (8.9)	.625 (15.9)
12	.811 (20.6)	1.551 (39.4)	.500 (12.7)	.750 (19.1)
16	.905 (23.0)	1.770 (45.0)	.625 (15.9)	.937 (23.8)
20	1.092 (27.7)	2.113 (53.7)	.875 (22.2)	1.250 (31.8)
24	1.124 (28.5)	2.363 (60.0)	1.000 (25.4)	1.375 (34.9)
28	1.399 (35.5)	2.770 (70.4)	1.250 (31.8)	1.625 (41.3)
32	1.399 (35.5)	3.020 (76.7)	1.437 (36.5)	1.875 (47.6)

- When maximum cable entry (page 21) is exceeded, Style 2 will be supplied. Dimensions E, F, G and H will not apply. Please consult factory.
- Metric dimensions (mm) are indicated in parentheses.
- Cable range is defined as the accommodations range for the wire bundle or cable. Dimensions shown are not intended for inspection criteria.
- Consult factory for shorter lengths on straight backshells.

TABLE XI: CABLE ENTRY

Dash No.	W Max	X Max	Y Max	Z Max	Cable Range	
					Min **	Max
03*	.437 (11.1)	.760 (19.3)	.843 (21.4)	.630 (16.0)	.156 (4.0)	.250 (6.4)
04*	.437 (11.1)	.760 (19.3)	.906 (23.0)	.755 (19.2)	.188 (4.8)	.312 (7.9)
06*	.500 (12.7)	.760 (19.3)	1.093 (27.8)	.942 (23.9)	.281 (7.1)	.438 (11.1)
08	.563 (14.3)	.760 (19.3)	1.187 (30.1)	1.067 (27.1)	.344 (8.7)	.562 (14.3)
10	.563 (14.3)	.760 (19.3)	1.281 (32.5)	1.192 (30.3)	.375 (9.5)	.625 (15.9)
12	.563 (14.3)	.760 (19.3)	1.500 (38.1)	1.380 (35.1)	.438 (11.1)	.750 (19.1)
16	.656 (16.7)	1.073 (27.3)	1.719 (43.7)	1.535 (39.0)	.562 (14.3)	.938 (23.8)
20	.656 (16.7)	1.323 (33.6)	2.062 (52.4)	1.848 (46.9)	.750 (19.1)	1.250 (31.8)
24	.656 (16.7)	1.323 (33.6)	2.312 (58.7)	2.255 (57.3)	.781 (19.8)	1.375 (34.9)
28	1.188 (30.2)	1.572 (39.9)	2.719 (69.1)	2.505 (63.6)	.969 (24.6)	1.625 (41.3)
32*	1.187 (30.1)	1.572 (39.9)	2.969 (75.4)	2.755 (70.0)	1.125 (28.6)	1.875 (47.6)
40*	1.125 (28.6)	1.572 (39.9)	3.531 (89.7)	3.255 (82.7)	1.469 (37.3)	2.375 (60.3)

* Not available in Style M clamp. ** Not Applicable Style D

**CONNECTOR
DESIGNATORS**

**A-F-H-L-S
ROTATABLE
COUPLING**

**TYPE D INDIVIDUAL
OR OVERALL
SHIELD TERMINATION**

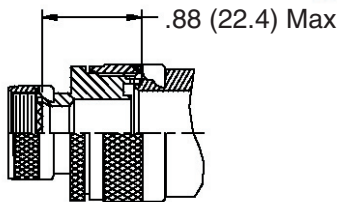
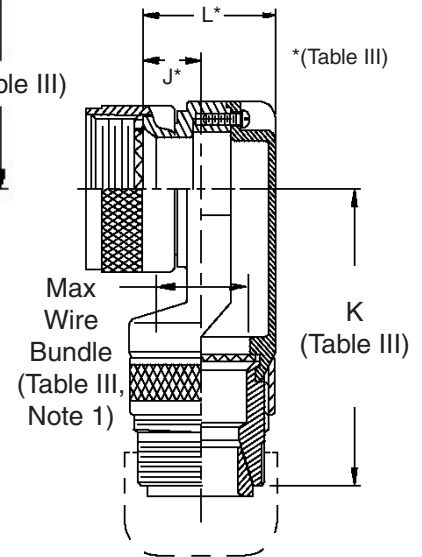
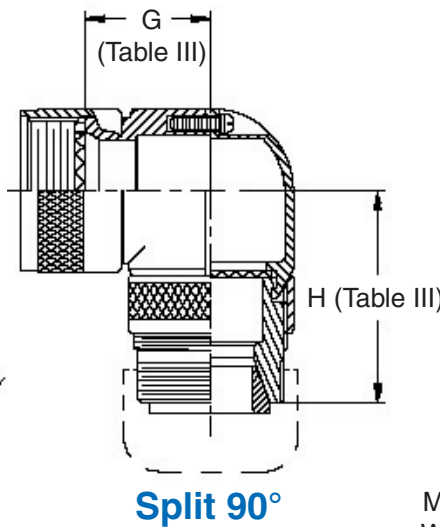
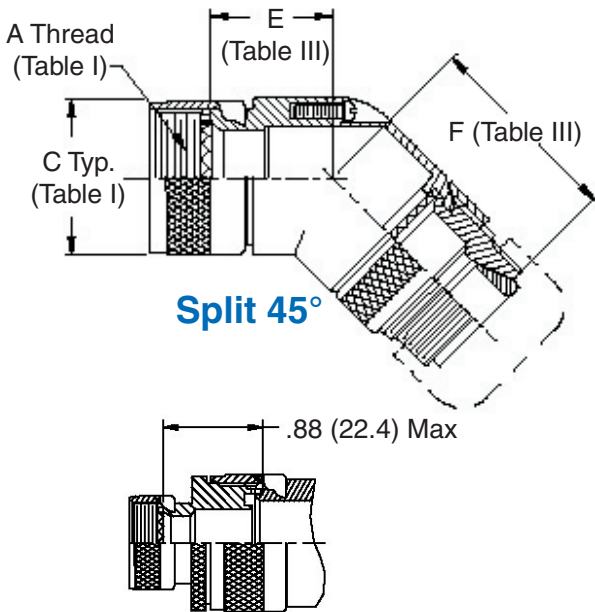
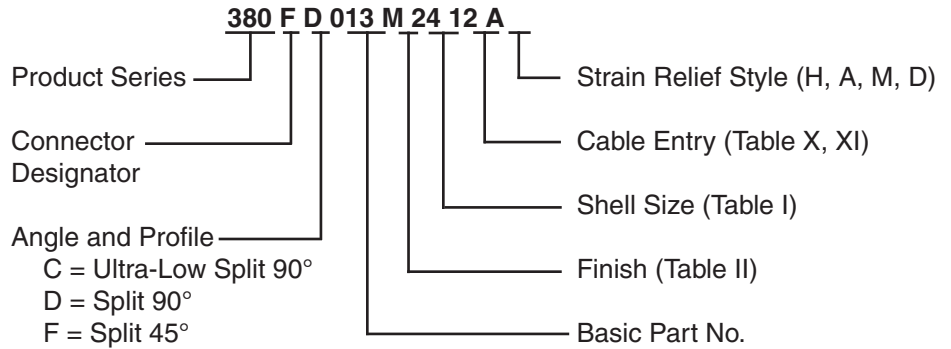

STYLE H
Heavy Duty
(Table X)

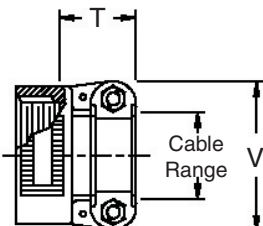

STYLE A
Medium Duty
(Table XI)

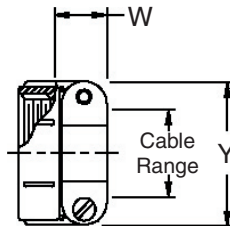

STYLE M
Medium Duty
(Table XI)

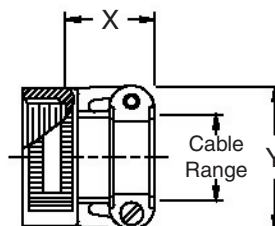

STYLE D
Medium Duty
(Table XI)

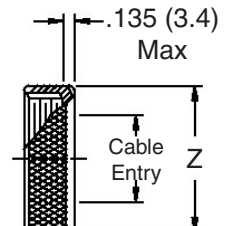

See inside back cover fold-out or pages 13 and 14 for unabridged Tables I and II.

TABLE III: DIMENSIONS

Shell Size	E Max	F Max	G Max	H Max	J Ref	K Max	L Max	Function C Max Wire Bundle
08/09	.440 (11.2)	1.730 (43.9)	.680 (17.3)	1.670 (42.4)	.340 (8.6)	1.920 (48.8)	.681 (17.3)	.250 (6.4)
10/11	.500 (12.7)	1.785 (45.3)	.750 (19.1)	1.725 (43.8)	.270 (6.9)	2.080 (52.8)	.731 (18.6)	.375 (9.5)
12/13	.560 (14.2)	1.855 (47.1)	.810 (20.6)	1.795 (45.6)	.270 (6.9)	2.080 (52.8)	.731 (18.6)	.375 (9.5)
14/15	.620 (15.7)	1.887 (47.9)	.870 (22.1)	1.827 (46.4)	.320 (8.1)	2.150 (54.6)	.831 (21.1)	.500 (12.7)
16/17	.680 (17.3)	1.987 (50.5)	.930 (23.6)	1.927 (48.9)	.420 (10.7)	2.200 (55.9)	.981 (24.9)	.625 (15.9)
18/19	.750 (19.1)	2.045 (51.9)	1.000 (25.4)	1.985 (50.4)	.640 (16.3)	2.230 (56.6)	1.181 (30.0)	.625 (15.9)
20/21	.820 (20.8)	2.106 (53.5)	1.060 (26.9)	2.046 (52.0)	.640 (16.3)	2.230 (56.6)	1.181 (30.0)	.625 (15.9)
22/23	.880 (22.4)	2.167 (55.0)	1.120 (28.4)	2.107 (53.5)	.540 (13.7)	2.380 (60.5)	1.181 (30.0)	.750 (19.1)
24/25	.940 (23.9)	2.225 (56.5)	1.180 (30.0)	2.165 (55.0)	.540 (13.7)	2.380 (60.5)	1.181 (30.0)	.750 (19.1)

TABLE X: CABLE ENTRY

Dash No.	T Max	V Max	Cable Range	
			Min	Max
04	.780 (19.8)	.957 (24.3)	.125 (3.2)	.312 (7.9)
06	.780 (19.8)	1.145 (29.1)	.250 (6.4)	.437 (11.1)
08	.780 (19.8)	1.332 (33.8)	.312 (7.9)	.562 (14.3)
10	.780 (19.8)	1.332 (33.8)	.350 (8.9)	.625 (15.9)
12	.811 (20.6)	1.551 (39.4)	.500 (12.7)	.750 (19.1)
16	.905 (23.0)	1.770 (45.0)	.625 (15.9)	.937 (23.8)
20	1.092 (27.7)	2.113 (53.7)	.875 (22.2)	1.250 (31.8)
24	1.124 (28.5)	2.363 (60.0)	1.000 (25.4)	1.375 (34.9)
28	1.399 (35.5)	2.770 (70.4)	1.250 (31.8)	1.625 (41.3)
32	1.399 (35.5)	3.020 (76.7)	1.437 (36.5)	1.875 (47.6)

TABLE II: STANDARD FINISHES

GLENAIR	
SYMBOL	FINISH
B	Cadmium Plate, Olive Drab
M	Electroless Nickel
NF	Cadmium Plate, Olive Drab Over Electroless Nickel
See Inside Back Cover for Additional Finish Options	

- When maximum cable entry (page 21) is exceeded, Style 2 will be supplied (not available in Function C). Dimensions E, F, G and H will not apply. Please consult factory.
- Metric dimensions (mm) are indicated in parentheses.

TABLE XI: CABLE ENTRY

Dash No.	W Max	X Max	Y Max	Z Max	Cable Range	
					Min **	Max
03*	.437 (11.1)	.760 (19.3)	.843 (21.4)	.630 (16.0)	.156 (4.0)	.250 (6.4)
04*	.437 (11.1)	.760 (19.3)	.906 (23.0)	.755 (19.2)	.188 (4.8)	.312 (7.9)
06*	.500 (12.7)	.760 (19.3)	1.093 (27.8)	.942 (23.9)	.281 (7.1)	.438 (11.1)
08	.563 (14.3)	.760 (19.3)	1.187 (30.1)	1.067 (27.1)	.344 (8.7)	.562 (14.3)
10	.563 (14.3)	.760 (19.3)	1.281 (32.5)	1.192 (30.3)	.375 (9.5)	.625 (15.9)
12	.563 (14.3)	.760 (19.3)	1.500 (38.1)	1.380 (35.1)	.438 (11.1)	.750 (19.1)
16	.656 (16.7)	1.073 (27.3)	1.719 (43.7)	1.535 (39.0)	.562 (14.3)	.938 (23.8)
20	.656 (16.7)	1.323 (33.6)	2.062 (52.4)	1.848 (46.9)	.750 (19.1)	1.250 (31.8)
24	.656 (16.7)	1.323 (33.6)	2.312 (58.7)	2.255 (57.3)	.781 (19.8)	1.375 (34.9)
28	1.188 (30.2)	1.572 (39.9)	2.719 (69.1)	2.505 (63.6)	.969 (24.6)	1.625 (41.3)
32*	1.187 (30.1)	1.572 (39.9)	2.969 (75.4)	2.755 (70.0)	1.125 (28.6)	1.875 (47.6)
40*	1.125 (28.6)	1.572 (39.9)	3.531 (89.7)	3.255 (82.7)	1.469 (37.3)	2.375 (60.3)

* Not available in Style M clamp. ** Not Applicable Style D

- Cable range is defined as the accommodations range for the wire bundle or cable. Dimensions shown are not intended for inspection criteria.
- Angular function "C", low-profile split elbow, not available with "S" connector designator.