

**CONNECTOR
DESIGNATORS
A-F-H-L-S
ROTATABLE
COUPLING**

**TYPE F INDIVIDUAL
AND/OR OVERALL
SHIELD TERMINATION**

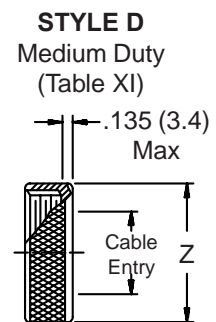

380-103
EMI/RFI Non-Environmental Backshell
with Strain Relief
Type F - Rotatable Coupling - Standard Profile

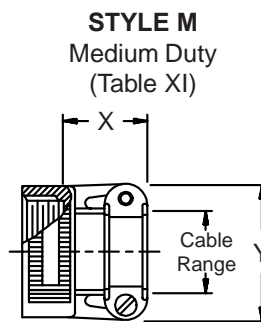
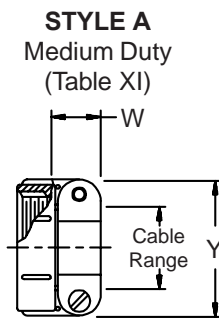
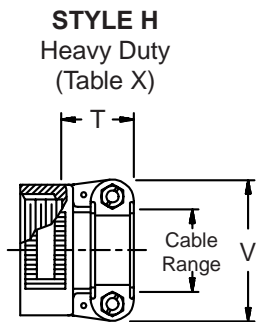
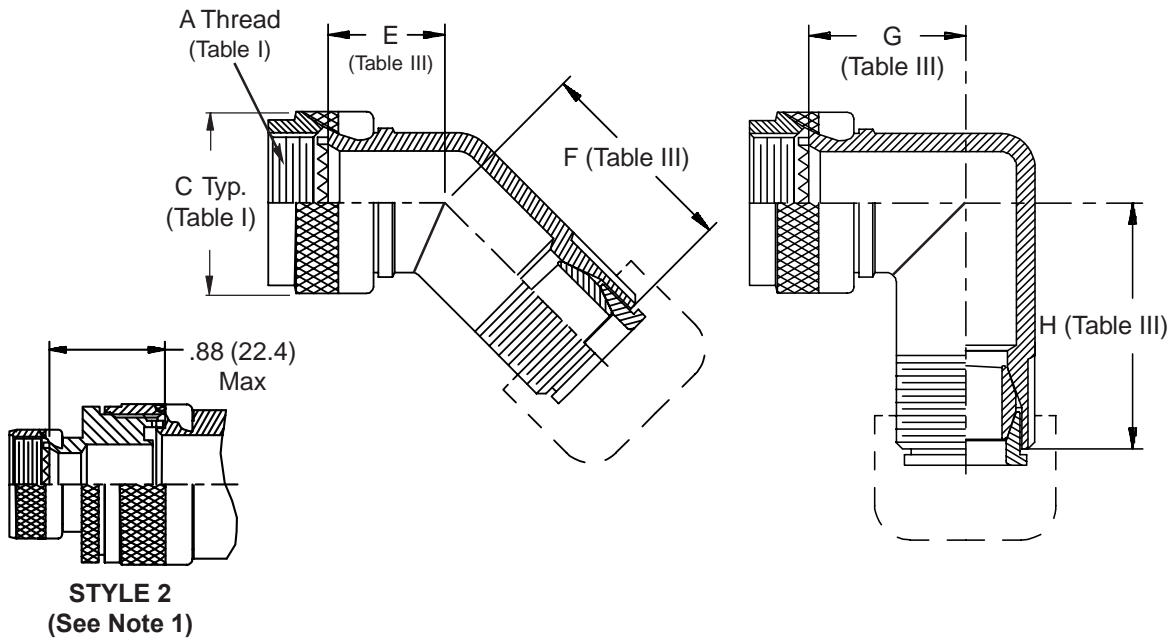
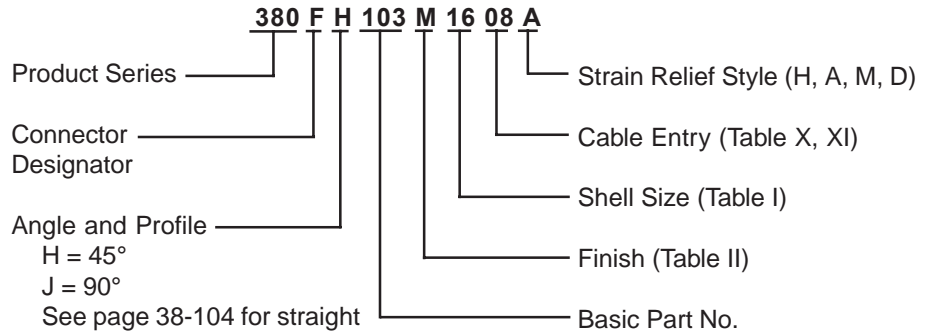

TABLE III: ELBOW DIMENSIONS

Shell Size		E Max	F Max	G Max	H Max
Conn. Desig. A-F-L-S	H				
08	09	.639 (16.2)	1.015 (25.8)	.750 (19.1)	1.125 (28.6)
10	11	.664 (16.9)	1.045 (26.5)	.810 (20.6)	1.185 (30.1)
12	13	.688 (17.5)	1.065 (27.1)	.870 (22.1)	1.245 (31.6)
14	15	.705 (17.9)	1.095 (27.8)	.920 (23.4)	1.315 (33.4)
16	17	.732 (18.6)	1.115 (28.3)	.980 (24.9)	1.375 (34.9)
18	19	.748 (19.0)	1.125 (28.6)	1.020 (25.9)	1.395 (35.4)
20	21	.773 (19.6)	1.145 (29.1)	1.080 (27.4)	1.445 (36.7)
22	23	.800 (20.3)	1.185 (30.1)	1.140 (29.0)	1.535 (39.0)
24	25	.823 (20.9)	1.215 (30.9)	1.200 (30.5)	1.605 (40.8)

TABLE II: STANDARD FINISHES

GLENAIR SYMBOL	FINISH
B	Cadmium Plate, Olive Drab
M	Electroless Nickel
NF	Cadmium Plate, Olive Drab Over Electroless Nickel

See Inside Back Cover
for Additional Finish Options

**See inside back cover
fold-out or pages 13 and
14 for unabridged
Tables I and II.**

TABLE X: CABLE ENTRY

Dash No.	T Max	V Max	Cable Range	
			Min	Max
04	.780 (19.8)	.957 (24.3)	.125 (3.2)	.312 (7.9)
06	.780 (19.8)	1.145 (29.1)	.250 (6.4)	.437 (11.1)
08	.780 (19.8)	1.332 (33.8)	.312 (7.9)	.562 (14.3)
10	.780 (19.8)	1.332 (33.8)	.350 (8.9)	.625 (15.9)
12	.811 (20.6)	1.551 (39.4)	.500 (12.7)	.750 (19.1)
16	.905 (23.0)	1.770 (45.0)	.625 (15.9)	.937 (23.8)
20	1.092 (27.7)	2.113 (53.7)	.875 (22.2)	1.250 (31.8)
24	1.124 (28.5)	2.363 (60.0)	1.000 (25.4)	1.375 (34.9)
28	1.399 (35.5)	2.770 (70.4)	1.250 (31.8)	1.625 (41.3)
32	1.399 (35.5)	3.020 (76.7)	1.437 (36.5)	1.875 (47.6)

- When maximum cable entry (page 21) is exceeded, Style 2 will be supplied. Dimensions E, F, G and H will not apply. Please consult factory.
- Metric dimensions (mm) are indicated in parentheses.
- Cable range is defined as the accommodations range for the wire bundle or cable. Dimensions shown are not intended for inspection criteria.
- 445 modification not available for MIL-DTL-38999 Series II.

TABLE XI: CABLE ENTRY

Dash No.	W Max	X Max	Y Max	Z Max	Cable Range	
					Min **	Max
03*	.437 (11.1)	.760 (19.3)	.843 (21.4)	.630 (16.0)	.156 (4.0)	.250 (6.4)
04*	.437 (11.1)	.760 (19.3)	.906 (23.0)	.755 (19.2)	.188 (4.8)	.312 (7.9)
06*	.500 (12.7)	.760 (19.3)	1.093 (27.8)	.942 (23.9)	.281 (7.1)	.438 (11.1)
08	.563 (14.3)	.760 (19.3)	1.187 (30.1)	1.067 (27.1)	.344 (8.7)	.562 (14.3)
10	.563 (14.3)	.760 (19.3)	1.281 (32.5)	1.192 (30.3)	.375 (9.5)	.625 (15.9)
12	.563 (14.3)	.760 (19.3)	1.500 (38.1)	1.380 (35.1)	.438 (11.1)	.750 (19.1)
16	.656 (16.7)	1.073 (27.3)	1.719 (43.7)	1.535 (39.0)	.562 (14.3)	.938 (23.8)
20	.656 (16.7)	1.323 (33.6)	2.062 (52.4)	1.848 (46.9)	.750 (19.1)	1.250 (31.8)
24	.656 (16.7)	1.323 (33.6)	2.312 (58.7)	2.255 (57.3)	.781 (19.8)	1.375 (34.9)
28	1.188 (30.2)	1.572 (39.9)	2.719 (69.1)	2.505 (63.6)	.969 (24.6)	1.625 (41.3)
32*	1.187 (30.1)	1.572 (39.9)	2.969 (75.4)	2.755 (70.0)	1.125 (28.6)	1.875 (47.6)
40*	1.125 (28.6)	1.572 (39.9)	3.531 (89.7)	3.255 (82.7)	1.469 (37.3)	2.375 (60.3)

* Not available in Style M clamp. ** Not Applicable Style D

-445 Add "-445" to Specify Glenair's Non-Detent, ("NESTOR") Spring-Loaded, Self-Locking Coupling. See Page 41 for Details.

**CONNECTOR
 DESIGNATORS
 A-F-H-L-S
 ROTATABLE
 COUPLING**

**TYPE F INDIVIDUAL
 AND/OR OVERALL
 SHIELD TERMINATION**

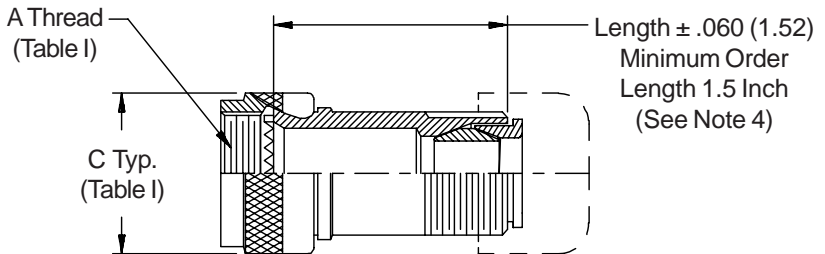
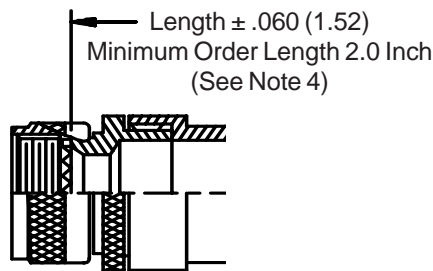
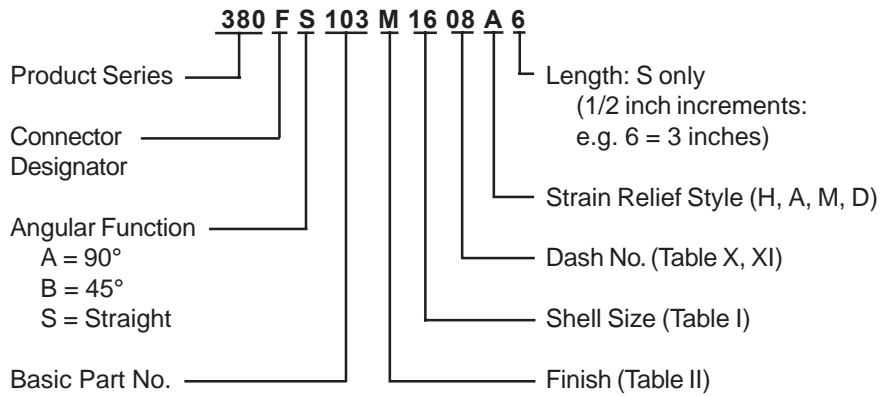

**STYLE 2
 (STRAIGHT
 See Note 1)**

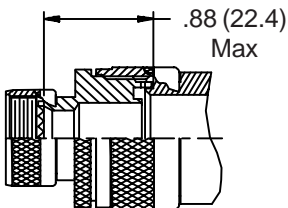

**STYLE 2
 (45° & 90°
 See Note 1)**

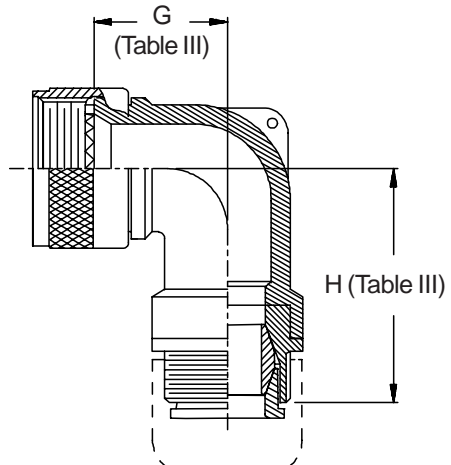
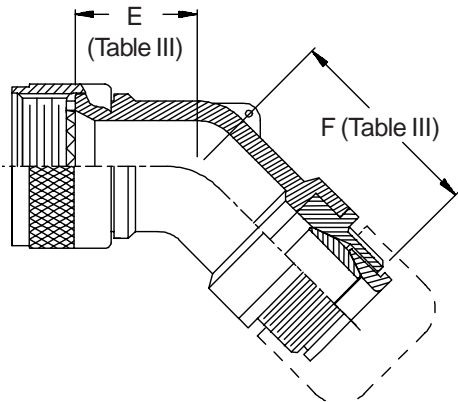

**STYLE H
 Heavy Duty
 (Table X)**

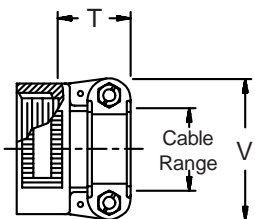

**STYLE A
 Medium Duty
 (Table XI)**

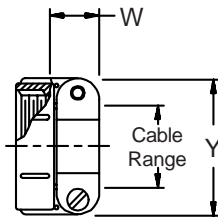

**STYLE M
 Medium Duty
 (Table XI)**

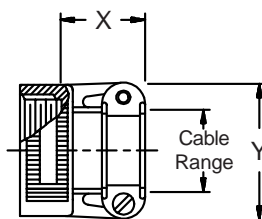

**STYLE D
 Medium Duty
 (Table XI)**

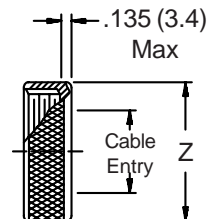

380-103
EMI/RFI Non-Environmental Backshell
with Strain Relief
Type F - Rotatable Coupling - Low Profile



TABLE III: ELBOW DIMENSIONS

Shell Size		E		F		G		H	
Conn. Desig.		Max		Max		Max		Max	
A-F-L-S	H								
08	09	.457	(11.6)	1.602	(40.7)	.500	(12.7)	1.612	(40.9)
10	11	.520	(13.2)	1.662	(42.2)	.595	(15.1)	1.732	(44.0)
12	13	.582	(14.8)	1.722	(43.7)	.610	(15.5)	1.752	(44.5)
14	15	.645	(16.4)	2.062	(52.4)	.700	(17.8)	2.072	(52.6)
16	17	.738	(18.7)	2.172	(55.2)	.885	(22.5)	2.162	(54.9)
18	19	.926	(23.5)	2.362	(60.0)	.975	(24.8)	2.332	(59.2)
20	21	.926	(23.5)	2.362	(60.0)	.975	(24.8)	2.332	(59.2)
22	23	1.020	(25.9)	2.512	(63.8)	1.125	(28.6)	2.442	(62.0)
24	25	1.020	(25.9)	2.512	(63.8)	1.125	(28.6)	2.442	(62.0)
28		1.145	(29.1)	2.562	(65.1)	1.225	(31.1)	2.612	(66.3)

TABLE II: STANDARD FINISHES

GLENAIR SYMBOL	FINISH
B	Cadmium Plate, Olive Drab
M	Electroless Nickel
NF	Cadmium Plate, Olive Drab Over Electroless Nickel

See Inside Back Cover for Additional Finish Options

See inside back cover fold-out or pages 13 and 14 for unabridged Tables I and II.

TABLE X: CABLE ENTRY

Dash No.	T Max	V Max	Cable Range	
			Min	Max
04	.780 (19.8)	.957 (24.3)	.125 (3.2)	.312 (7.9)
06	.780 (19.8)	1.145 (29.1)	.250 (6.4)	.437 (11.1)
08	.780 (19.8)	1.332 (33.8)	.312 (7.9)	.562 (14.3)
10	.780 (19.8)	1.332 (33.8)	.350 (8.9)	.625 (15.9)
12	.811 (20.6)	1.551 (39.4)	.500 (12.7)	.750 (19.1)
16	.905 (23.0)	1.770 (45.0)	.625 (15.9)	.937 (23.8)
20	1.092 (27.7)	2.113 (53.7)	.875 (22.2)	1.250 (31.8)
24	1.124 (28.5)	2.363 (60.0)	1.000 (25.4)	1.375 (34.9)
28	1.399 (35.5)	2.770 (70.4)	1.250 (31.8)	1.625 (41.3)
32	1.399 (35.5)	3.020 (76.7)	1.437 (36.5)	1.875 (47.6)

1. When maximum cable entry (page 21) is exceeded, Style 2 will be supplied. Dimensions E, F, G and H will not apply. Please consult factory.
2. Metric dimensions (mm) are indicated in parentheses.
3. Cable range is defined as the accommodations range for the wire bundle or cable. Dimensions shown are not intended for inspection criteria.
4. Consult factory for shorter lengths on straight backshells.

TABLE XI: CABLE ENTRY

Dash No.	W Max	X Max	Y Max	Z Max	Cable Range	
					Min **	Max
03*	.437 (11.1)	.760 (19.3)	.843 (21.4)	.630 (16.0)	.156 (4.0)	.250 (6.4)
04*	.437 (11.1)	.760 (19.3)	.906 (23.0)	.755 (19.2)	.188 (4.8)	.312 (7.9)
06*	.500 (12.7)	.760 (19.3)	1.093 (27.8)	.942 (23.9)	.281 (7.1)	.438 (11.1)
08	.563 (14.3)	.760 (19.3)	1.187 (30.1)	1.067 (27.1)	.344 (8.7)	.562 (14.3)
10	.563 (14.3)	.760 (19.3)	1.281 (32.5)	1.192 (30.3)	.375 (9.5)	.625 (15.9)
12	.563 (14.3)	.760 (19.3)	1.500 (38.1)	1.380 (35.1)	.438 (11.1)	.750 (19.1)
16	.656 (16.7)	1.073 (27.3)	1.719 (43.7)	1.535 (39.0)	.562 (14.3)	.938 (23.8)
20	.656 (16.7)	1.323 (33.6)	2.062 (52.4)	1.848 (46.9)	.750 (19.1)	1.250 (31.8)
24	.656 (16.7)	1.323 (33.6)	2.312 (58.7)	2.255 (57.3)	.781 (19.8)	1.375 (34.9)
28	1.188 (30.2)	1.572 (39.9)	2.719 (69.1)	2.505 (63.6)	.969 (24.6)	1.625 (41.3)
32	1.187 (30.1)	1.572 (39.9)	2.969 (75.4)	2.755 (70.0)	1.125 (28.6)	1.875 (47.6)

* Not available in Style M clamp. ** Not Applicable Style D

**CONNECTOR
 DESIGNATORS
 A-F-H-L-S
 ROTATABLE
 COUPLING**

**TYPE F INDIVIDUAL
 AND/OR OVERALL
 SHIELD TERMINATION**

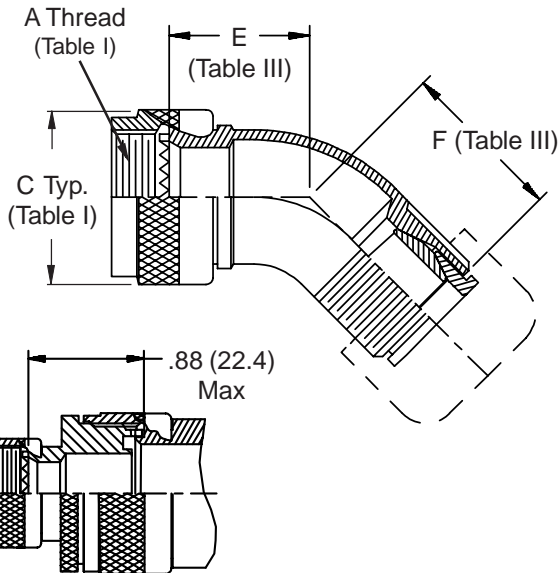
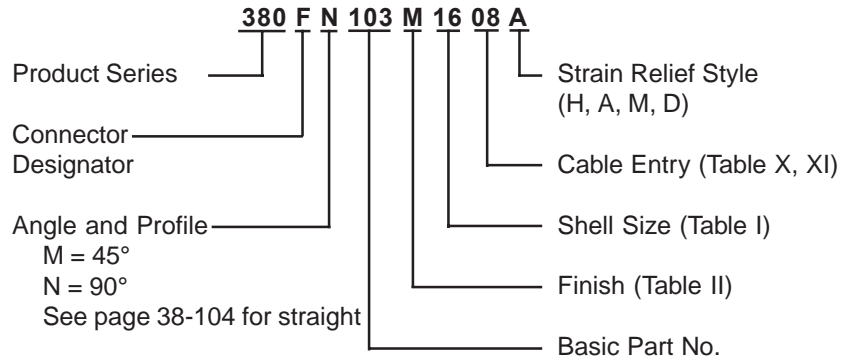

STYLE 2
 (See Note 1)

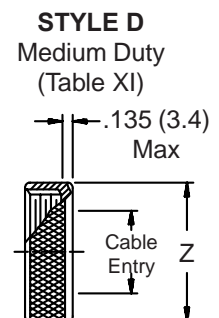
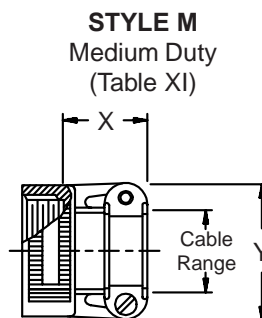
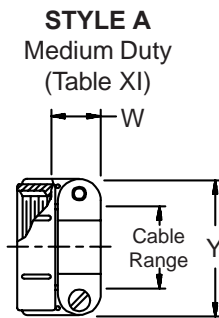
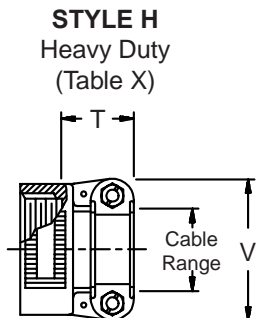
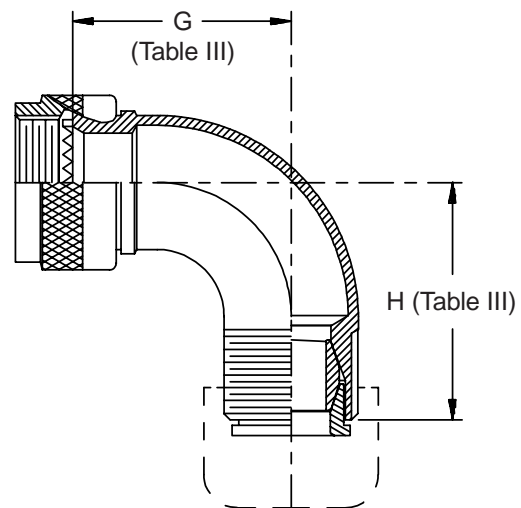

380-103
EMI/RFI Non-Environmental Backshell
with Strain Relief
Type F - Rotatable Coupling - Full Radius Profile



TABLE III: ELBOW DIMENSIONS

Shell Size		E		F		G		H	
Conn. Desig.	A-F-L-S H	Max		Max		Max		Max	
08	09	.812	(20.6)	.875	(22.2)	1.125	(28.6)	1.188	(30.2)
10	11	.875	(22.2)	.938	(23.8)	1.250	(31.8)	1.312	(33.3)
12	13	.938	(23.8)	1.000	(25.4)	1.375	(34.9)	1.438	(36.5)
14	15	1.000	(25.4)	1.062	(27.0)	1.500	(38.1)	1.562	(39.7)
16	17	1.062	(27.0)	1.125	(28.6)	1.625	(41.3)	1.688	(42.9)
18	19	1.094	(27.8)	1.156	(29.4)	1.750	(44.5)	1.812	(46.0)
20	21	1.156	(29.4)	1.219	(31.0)	1.875	(47.6)	1.938	(49.2)
22	23	1.188	(30.2)	1.250	(31.8)	2.000	(50.8)	2.062	(52.4)
24	25	1.250	(31.8)	1.312	(33.3)	2.125	(54.0)	2.188	(55.6)
28		1.344	(34.1)	1.625	(41.3)	2.375	(60.3)	2.625	(66.7)

TABLE II: STANDARD FINISHES

GLENAIR	
SYMBOL	FINISH
B	Cadmium Plate, Olive Drab
M	Electroless Nickel
NF	Cadmium Plate, Olive Drab Over Electroless Nickel
See Inside Back Cover for Additional Finish Options	

**See inside back cover
fold-out or pages 13 and
14 for unabridged
Tables I and II.**

TABLE X: CABLE ENTRY

Dash No.	T Max	V Max	Cable Range			
			Min	Max	Min	Max
04	.780 (19.8)	.957 (24.3)	.125 (3.2)	.312 (7.9)		
06	.780 (19.8)	1.145 (29.1)	.250 (6.4)	.437 (11.1)		
08	.780 (19.8)	1.332 (33.8)	.312 (7.9)	.562 (14.3)		
10	.780 (19.8)	1.332 (33.8)	.350 (8.9)	.625 (15.9)		
12	.811 (20.6)	1.551 (39.4)	.500 (12.7)	.750 (19.1)		
16	.905 (23.0)	1.770 (45.0)	.625 (15.9)	.937 (23.8)		
20	1.092 (27.7)	2.113 (53.7)	.875 (22.2)	1.250 (31.8)		
24	1.124 (28.5)	2.363 (60.0)	1.000 (25.4)	1.375 (34.9)		
28	1.399 (35.5)	2.770 (70.4)	1.250 (31.8)	1.625 (41.3)		
32	1.399 (35.5)	3.020 (76.7)	1.437 (36.5)	1.875 (47.6)		

1. When maximum cable entry (page 21) is exceeded, Style 2 will be supplied. Dimensions E, F, G and H will not apply. Please consult factory.
2. Metric dimensions (mm) are indicated in parentheses.
3. Cable range is defined as the accommodations range for the wire bundle or cable. Dimensions shown are not intended for inspection criteria.

TABLE XI: CABLE ENTRY

Dash No.	W Max	X Max	Y Max	Z Max	Cable Range	
					Min **	Max
03*	.437 (11.1)	.760 (19.3)	.843 (21.4)	.630 (16.0)	.156 (4.0)	.250 (6.4)
04*	.437 (11.1)	.760 (19.3)	.906 (23.0)	.755 (19.2)	.188 (4.8)	.312 (7.9)
06*	.500 (12.7)	.760 (19.3)	1.093 (27.8)	.942 (23.9)	.281 (7.1)	.438 (11.1)
08	.563 (14.3)	.760 (19.3)	1.187 (30.1)	1.067 (27.1)	.344 (8.7)	.562 (14.3)
10	.563 (14.3)	.760 (19.3)	1.281 (32.5)	1.192 (30.3)	.375 (9.5)	.625 (15.9)
12	.563 (14.3)	.760 (19.3)	1.500 (38.1)	1.380 (35.1)	.438 (11.1)	.750 (19.1)
16	.656 (16.7)	1.073 (27.3)	1.719 (43.7)	1.535 (39.0)	.562 (14.3)	.938 (23.8)
20	.656 (16.7)	1.323 (33.6)	2.062 (52.4)	1.848 (46.9)	.750 (19.1)	1.250 (31.8)
24	.656 (16.7)	1.323 (33.6)	2.312 (58.7)	2.255 (57.3)	.781 (19.8)	1.375 (34.9)
28	1.188 (30.2)	1.572 (39.9)	2.719 (69.1)	2.505 (63.6)	.969 (24.6)	1.625 (41.3)
32*	1.187 (30.1)	1.572 (39.9)	2.969 (75.4)	2.755 (70.0)	1.125 (28.6)	1.875 (47.6)
40*	1.125 (28.6)	1.572 (39.9)	3.531 (89.7)	3.255 (82.7)	1.469 (37.3)	2.375 (60.3)

* Not available in Style M clamp. ** Not Applicable Style D

**CONNECTOR
DESIGNATORS**

**A-F-H-L-S
ROTATABLE
COUPLING**

**TYPE F INDIVIDUAL
AND/OR OVERALL
SHIELD TERMINATION**

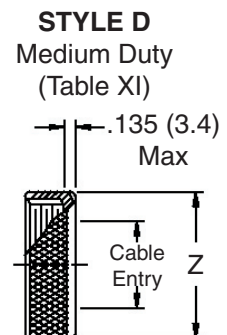
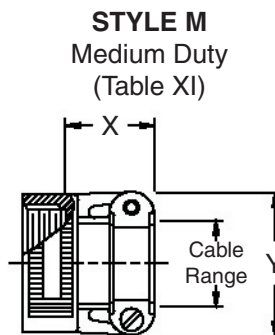
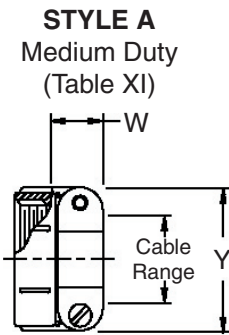
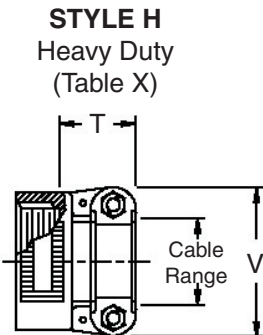
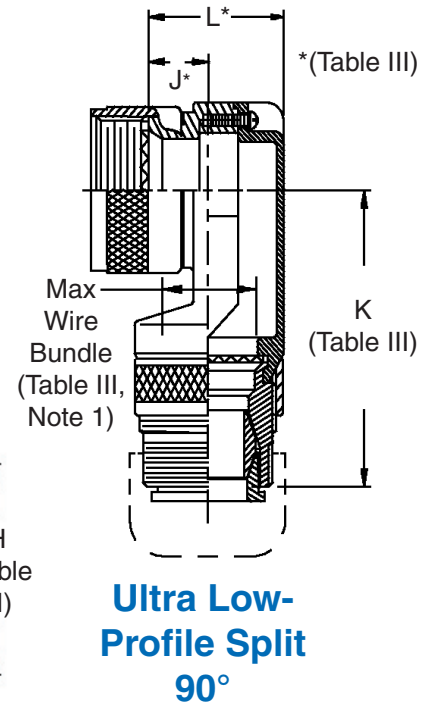
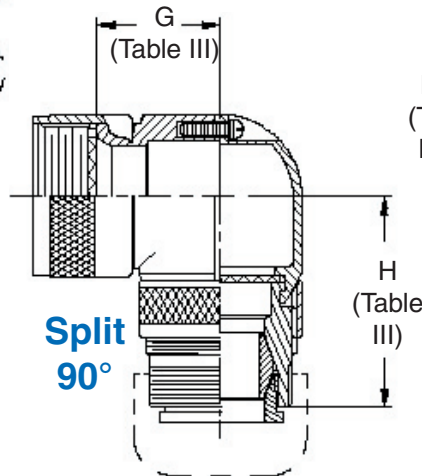
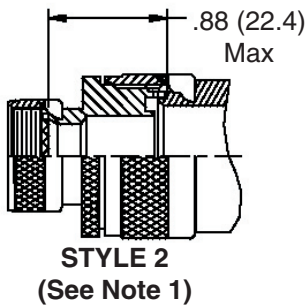
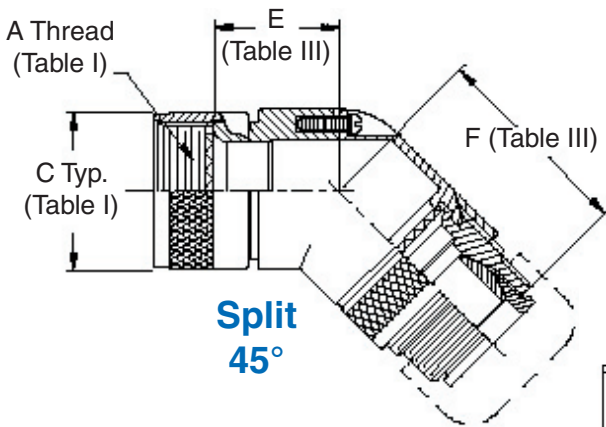
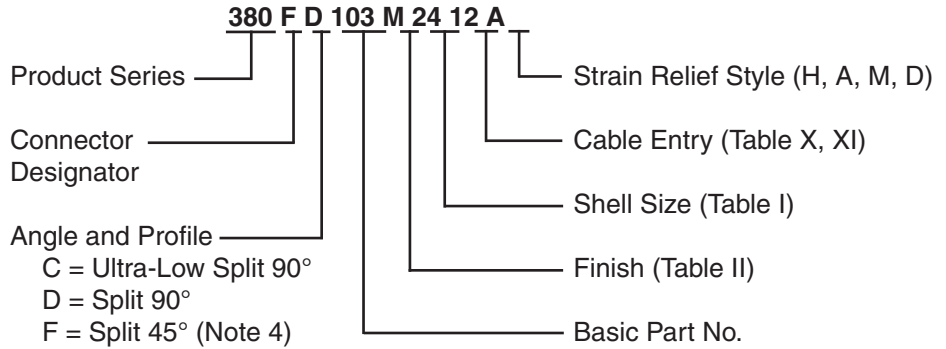

TABLE III: ELBOW DIMENSIONS

Shell Size	E Max	F Max	G Max	H Max	J Ref	K Max	L Max	Function C Max Wire Bundle
08/09	.440 (11.2)	1.590 (40.4)	.680 (17.3)	1.530 (38.9)	.340 (8.6)	1.780 (45.2)	.681 (17.3)	.250 (6.4)
10/11	.500 (12.7)	1.650 (41.9)	.750 (19.1)	1.590 (40.4)	.270 (6.9)	1.940 (49.3)	.731 (18.6)	.375 (9.5)
12/13	.560 (14.2)	1.720 (43.7)	.810 (20.6)	1.660 (42.2)	.270 (6.9)	1.940 (49.3)	.731 (18.6)	.375 (9.5)
14/15	.620 (15.7)	1.750 (44.5)	.870 (22.1)	1.690 (42.9)	.320 (8.1)	2.010 (51.1)	.831 (21.1)	.500 (12.7)
16/17	.680 (17.3)	1.850 (47.0)	.930 (23.6)	1.790 (45.5)	.420 (10.7)	2.060 (52.3)	.981 (24.9)	.625 (15.9)
18/19	.750 (19.1)	1.910 (48.5)	1.000 (25.4)	1.850 (47.0)	.640 (16.3)	2.090 (53.1)	1.181 (30.0)	.625 (15.9)
20/21	.820 (20.8)	1.970 (50.0)	1.060 (26.9)	1.910 (48.5)	.640 (16.3)	2.090 (53.1)	1.181 (30.0)	.625 (15.9)
22/23	.880 (22.4)	2.030 (51.6)	1.120 (28.4)	1.970 (50.0)	.540 (13.7)	2.240 (56.9)	1.181 (30.0)	.750 (19.1)
24/25	.940 (23.9)	2.090 (53.1)	1.180 (30.0)	2.030 (51.6)	.540 (13.7)	2.240 (56.9)	1.181 (30.0)	.750 (19.1)

TABLE X: CABLE ENTRY

Dash No.	T Max	V Max	Cable Range	
			Min	Max
04	.780 (19.8)	.957 (24.3)	.125 (3.2)	.312 (7.9)
06	.780 (19.8)	1.145 (29.1)	.250 (6.4)	.437 (11.1)
08	.780 (19.8)	1.332 (33.8)	.312 (7.9)	.562 (14.3)
10	.780 (19.8)	1.332 (33.8)	.350 (8.9)	.625 (15.9)
12	.811 (20.6)	1.551 (39.4)	.500 (12.7)	.750 (19.1)
16	.905 (23.0)	1.770 (45.0)	.625 (15.9)	.937 (23.8)
20	1.092 (27.7)	2.113 (53.7)	.875 (22.2)	1.250 (31.8)
24	1.124 (28.5)	2.363 (60.0)	1.000 (25.4)	1.375 (34.9)
28	1.399 (35.5)	2.770 (70.4)	1.250 (31.8)	1.625 (41.3)

TABLE II: STANDARD FINISHES

GLENAIR SYMBOL	FINISH
B	Cadmium Plate, Olive Drab
M	Electroless Nickel
NF	Cadmium Plate, Olive Drab Over Electroless Nickel

See Inside Back Cover for Additional Finish Options

See inside back cover fold-out or pages 13 and 14 for unabridged Tables I and II.

1. When maximum cable entry (page 21) is exceeded, Style 2 will be supplied (not available in Function C). Dimensions E, F, G and H will not apply. Please consult factory.
2. Metric dimensions (mm) are indicated in parentheses.
3. Cable range is defined as the accommodations range for the wire bundle or cable. Dimensions shown are not intended for inspection criteria.
4. Consult factory for available sizes of 45° (Function F).
5. Angular function "C", low-profile split elbow, not available with "S" connector designator.

TABLE XI: CABLE ENTRY

Dash No.	W Max	X Max	Y Max	Z Max	Cable Range	
					Min **	Max
03*	.437 (11.1)	.760 (19.3)	.843 (21.4)	.630 (16.0)	.156 (4.0)	.250 (6.4)
04*	.437 (11.1)	.760 (19.3)	.906 (23.0)	.755 (19.2)	.188 (4.8)	.312 (7.9)
06*	.500 (12.7)	.760 (19.3)	1.093 (27.8)	.942 (23.9)	.281 (7.1)	.438 (11.1)
08	.563 (14.3)	.760 (19.3)	1.187 (30.1)	1.067 (27.1)	.344 (8.7)	.562 (14.3)
10	.563 (14.3)	.760 (19.3)	1.281 (32.5)	1.192 (30.3)	.375 (9.5)	.625 (15.9)
12	.563 (14.3)	.760 (19.3)	1.500 (38.1)	1.380 (35.1)	.438 (11.1)	.750 (19.1)
16	.656 (16.7)	1.073 (27.3)	1.719 (43.7)	1.535 (39.0)	.562 (14.3)	.938 (23.8)
20	.656 (16.7)	1.323 (33.6)	2.062 (52.4)	1.848 (46.9)	.750 (19.1)	1.250 (31.8)
24	.656 (16.7)	1.323 (33.6)	2.312 (58.7)	2.255 (57.3)	.781 (19.8)	1.375 (34.9)
28	1.188 (30.2)	1.572 (39.9)	2.719 (69.1)	2.505 (63.6)	.969 (24.6)	1.625 (41.3)

* Not available in Style M clamp. ** Not Applicable Style D