

**CONNECTOR
DESIGNATORS**
A-B*-C-D-E-F
G-H-J-K-L-S

* Conn. Desig. B See Note 5
DIRECT COUPLING

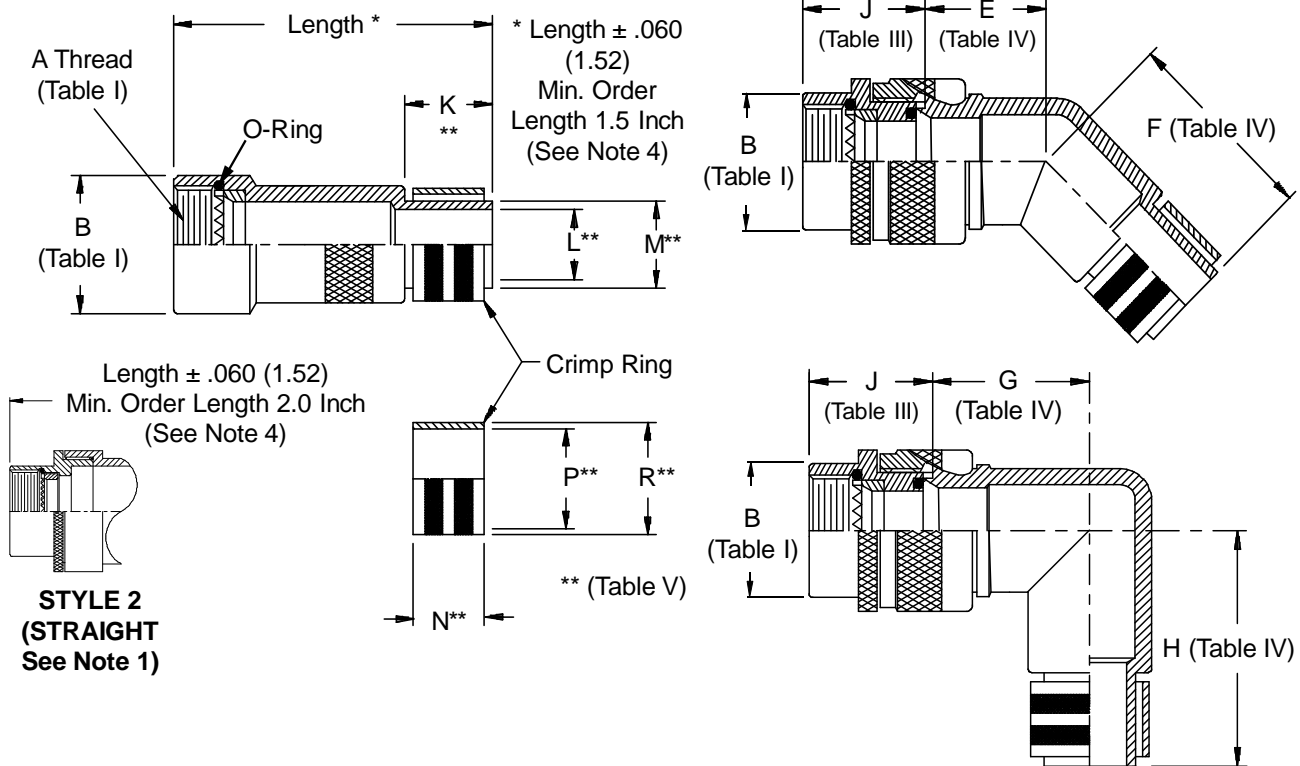
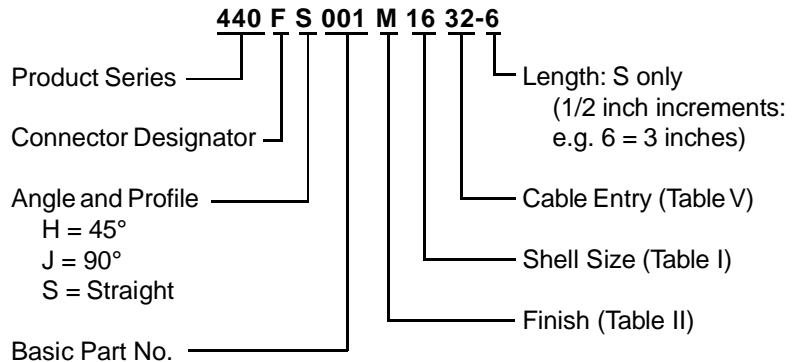

**STYLE 2
(STRAIGHT
See Note 1)**

See inside back cover fold-out or pages 13 and 14 for Tables I and II.

1. When maximum cable entry (page 22- Introduction) is exceeded, Style 2 will be supplied. (Function S only).
2. For proper installation of crimp ring, use Thomas & Betts (or equivalent) installation dies listed (Table V) for each dash no.
3. Metric dimensions (mm) are indicated in parentheses.
4. Consult factory for shorter lengths on straight backshells.
5. When using Connector Designator B refer to pages 18 and 19 for part number development.

440-001
EMI/RFI Crimp Ring Adapter
Direct Coupling - Standard Profile



440

TABLE III: FRONT ADAPTER

Shell Size	J Max - Conn. Designator		
	A-E-F		
	J-H-L-S	D-B-G-K	C
08/09	1.180 (30.0)	1.250 (31.8)	
10/11	1.180 (30.0)	1.250 (31.8)	
12/13	1.180 (30.0)	1.250 (31.8)	1.735 (44.1)
14/15	1.180 (30.0)	1.250 (31.8)	1.915 (48.6)
16/17	1.380 (35.0)	1.560 (39.6)	1.915 (48.6)
18/19	1.380 (35.0)	1.560 (39.6)	1.915 (48.6)
20/21	1.380 (35.0)	1.560 (39.6)	1.915 (48.6)
22/23	1.380 (35.0)	1.560 (39.6)	1.915 (48.6)
24/25	1.380 (35.0)	1.560 (39.6)	1.915 (48.6)
28/29	1.610 (40.9)	1.560 (39.6)	1.915 (48.6)
32/33	1.610 (40.9)	1.750 (44.5)	1.915 (48.6)
36	1.610 (40.9)	1.750 (44.5)	1.915 (48.6)
40	1.610 (40.9)	2.190 (55.6)	1.915 (48.6)

TABLE IV: ELBOW DIMENSIONS

Dash No.'s (Table V)	E Max	F Max	G Max	H Max
06-23	.639 (16.2)	.702 (17.8)	.750 (19.1)	.812 (20.6)
26-30	.664 (16.9)	.732 (18.6)	.812 (20.6)	.875 (22.2)
31-32	.688 (17.5)	1.040 (26.4)	.875 (22.2)	1.220 (31.0)
33	.705 (17.9)	1.070 (27.2)	.920 (23.4)	1.290 (32.8)
34	.732 (18.6)	1.090 (27.7)	.980 (24.9)	1.350 (34.3)
35	.773 (19.6)	1.100 (27.9)	1.020 (25.9)	1.370 (34.8)
36	.800 (20.3)	1.160 (29.5)	1.140 (29.0)	1.510 (38.4)
38-39	.823 (20.9)	1.190 (30.2)	1.200 (30.5)	1.580 (40.1)

TABLE V: CABLE ENTRY

Dash No.	K Nom	L Nom	M Nom	N Nom	P Nom	R Nom	Color Code (Ref.)	Inst. Die No. (Note 2)	Tool
06	.312 (7.9)	.090 (2.3)	.113 (2.9)	.250 (6.4)	.156 (4.0)	.194 (4.9)	Yellow	WT402	
10	.312 (7.9)	.124 (3.1)	.145 (3.7)	.250 (6.4)	.187 (4.7)	.227 (5.8)	Orange	WT406	
13	.312 (7.9)	.149 (3.8)	.179 (4.5)	.250 (6.4)	.225 (5.7)	.256 (6.5)	Purple	WT409	
16	.312 (7.9)	.175 (4.4)	.215 (5.5)	.250 (6.4)	.261 (6.6)	.297 (7.5)	Yellow	WT411	
20	.312 (7.9)	.219 (5.6)	.250 (6.4)	.250 (6.4)	.297 (7.5)	.335 (8.5)	Green	WT414	
23	.312 (7.9)	.250 (6.4)	.281 (7.1)	.250 (6.4)	.327 (8.3)	.372 (9.4)	Tin	WT416	
26	.312 (7.9)	.275 (7.0)	.306 (7.8)	.250 (6.4)	.375 (9.5)	.406 (10.3)	Yellow	WT440/5451	
29	.312 (7.9)	.297 (7.5)	.335 (8.5)	.250 (6.4)	.405 (10.3)	.453 (11.5)	Red	WT440/5452	
30	.312 (7.9)	.312 (7.9)	.365 (9.3)	.250 (6.4)	.425 (10.8)	.473 (12.0)	Tin	WT440/5454	
31	.312 (7.9)	.375 (9.5)	.406 (10.3)	.250 (6.4)	.500 (12.7)	.560 (14.2)	Green	WT440/5457	
32	.600 (15.2)	.430 (10.9)	.500 (12.7)	.440 (11.2)	.590 (15.0)	.670 (17.0)	Red	GS590	
33	.600 (15.2)	.550 (14.0)	.620 (15.7)	.440 (11.2)	.710 (18.0)	.790 (20.1)	Blue	GS710	
34	.600 (15.2)	.670 (17.0)	.750 (19.1)	.440 (11.2)	.840 (21.3)	.920 (23.4)	Gray	GS840	
35	.600 (15.2)	.810 (20.6)	.880 (22.4)	.440 (11.2)	1.010 (25.7)	1.090 (27.7)	Brown	GS1010	
36	.600 (15.2)	.920 (23.4)	1.000 (25.4)	.440 (11.2)	1.130 (28.7)	1.210 (30.7)	Green	GS1130	
38	.600 (15.2)	1.040 (26.4)	1.120 (28.4)	.440 (11.2)	1.250 (31.8)	1.330 (33.8)	Pink	GS1250	
39	.600 (15.2)	1.122 (28.5)	1.192 (30.3)	.440 (11.2)	1.332 (33.8)	1.412 (35.9)	Orange	GS1332	
40	.600 (15.2)	1.224 (31.1)	1.294 (32.9)	.440 (11.2)	1.440 (36.6)	1.520 (38.6)	Purple	GS1440	
41	.600 (15.2)	1.353 (34.4)	1.423 (36.1)	.440 (11.2)	1.562 (39.7)	1.643 (41.7)	Yellow	GS1563	
42	.600 (15.2)	1.425 (36.2)	1.545 (39.2)	.440 (11.2)	1.670 (42.4)	1.750 (44.5)	Red	GS1670	
43	.600 (15.2)	1.550 (39.4)	1.670 (42.4)	.440 (11.2)	1.795 (45.6)	1.875 (47.6)	Blue	GS1795	
44	.600 (15.2)	1.675 (42.5)	1.795 (45.6)	.440 (11.2)	1.920 (48.8)	2.000 (50.8)	Gray	GS1920	
45	.600 (15.2)	1.800 (45.7)	1.920 (48.8)	.440 (11.2)	2.045 (51.9)	2.125 (54.0)	Brown	GS2045	
46	.600 (15.2)	1.925 (48.9)	2.045 (51.9)	.440 (11.2)	2.170 (55.1)	2.250 (57.2)	Green	GS2170	
47	.600 (15.2)	2.050 (52.1)	2.170 (55.1)	.440 (11.2)	2.295 (58.3)	2.375 (60.3)	Pink	GS2295	
48	.600 (15.2)	2.175 (55.2)	2.295 (58.3)	.440 (11.2)	2.420 (61.5)	2.500 (63.5)	Orange	GS2420	
49	.600 (15.2)	2.300 (58.4)	2.420 (61.5)	.440 (11.2)	2.545 (64.6)	2.625 (66.7)	Purple	GS2545	
50	.600 (15.2)	2.425 (61.6)	2.545 (64.6)	.440 (11.2)	2.670 (67.8)	2.750 (69.9)	Yellow	GS2670	
51	.600 (15.2)	2.530 (64.3)	2.670 (67.8)	.440 (11.2)	2.795 (71.0)	2.875 (73.0)	Red	GS2795	
52	.600 (15.2)	2.655 (67.4)	2.795 (71.0)	.440 (11.2)	2.920 (74.2)	3.000 (76.2)	Blue	GS2920	
53	.600 (15.2)	2.780 (70.6)	2.920 (74.2)	.440 (11.2)	3.045 (77.3)	3.125 (79.4)	Gray	GS3045	
54	.600 (15.2)	2.905 (73.8)	3.045 (77.3)	.440 (11.2)	3.170 (80.5)	3.250 (82.6)	Brown	GS3170	

**CONNECTOR
 DESIGNATORS**
A-B*-C-D-E-F
G-H-J-K-L-S
 * Conn. Desig. B See Note 4
DIRECT COUPLING

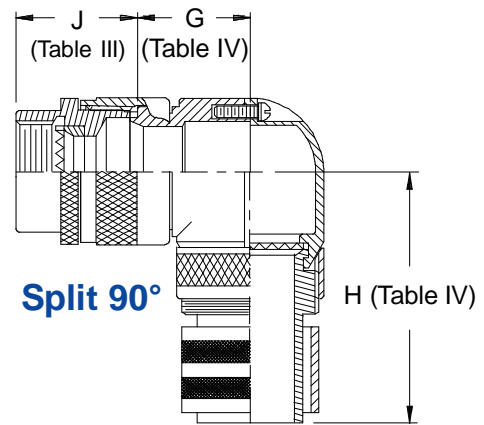
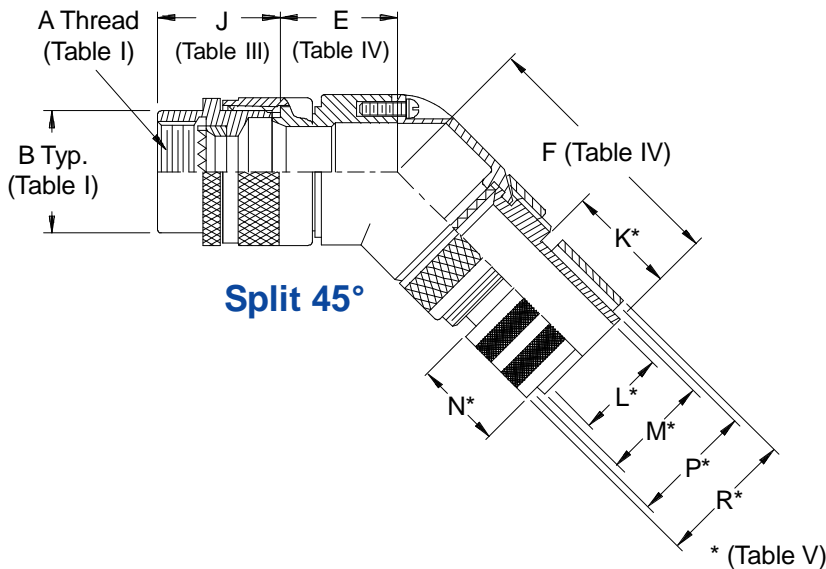
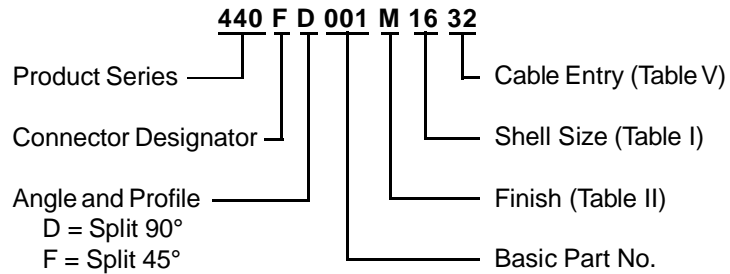

TABLE III: FRONT ADAPTER			
Shell Size	J Max - Conn. Designator		
	A-E-F	D-B-G-K	C
08/09	1.180 (30.0)	1.250 (31.8)	
10/11	1.180 (30.0)	1.250 (31.8)	
12/13	1.180 (30.0)	1.250 (31.8)	1.735 (44.1)
14/15	1.180 (30.0)	1.250 (31.8)	1.915 (48.6)
16/17	1.380 (35.0)	1.560 (39.6)	1.915 (48.6)
18/19	1.380 (35.0)	1.560 (39.6)	1.915 (48.6)
20/21	1.380 (35.0)	1.560 (39.6)	1.915 (48.6)
22/23	1.380 (35.0)	1.560 (39.6)	1.915 (48.6)
24/25	1.380 (35.0)	1.560 (39.6)	1.915 (48.6)
28/29	1.610 (40.9)	1.560 (39.6)	1.915 (48.6)
32/33	1.610 (40.9)	1.750 (44.5)	1.915 (48.6)
36	1.610 (40.9)	1.750 (44.5)	1.915 (48.6)
40	1.610 (40.9)	2.190 (55.6)	1.915 (48.6)

See inside back cover fold-out or pages 13 and 14 for Tables I and II.

1. For proper installation of crimp ring, use Thomas & Betts (or equivalent) installation dies listed (Table V) for each dash no.
2. Metric dimensions (mm) are indicated in parentheses.
3. Dimensions shown are not intended for inspection criteria.
4. When using Connector Designator B refer to pages 18 and 19 for part number development.

440-001
EMI/RFI Crimp Ring Adapter
Direct Coupling - Split Shell



440

TABLE IV: ELBOW DIMENSIONS

Dash No.'s (Table V)	E Max	F Max	G Max	H Max
06-23	.440 (11.2)	1.402 (35.6)	.680 (17.3)	1.342 (34.1)
26-30	.500 (12.7)	1.462 (37.1)	.750 (19.1)	1.402 (35.6)
31-32	.560 (14.2)	1.820 (46.2)	.810 (20.6)	1.760 (44.7)
33	.620 (15.7)	1.850 (47.0)	.870 (22.1)	1.790 (45.5)
34	.680 (17.3)	1.950 (49.5)	.930 (23.6)	1.890 (48.0)
35	.820 (20.8)	2.070 (52.6)	1.060 (26.9)	2.010 (51.1)
36	.880 (22.4)	2.130 (54.1)	1.120 (28.4)	2.070 (52.6)
38-39	.940 (23.9)	2.190 (55.6)	1.180 (30.0)	2.130 (54.1)

TABLE V: CABLE ENTRY

Dash No.	K Nom	L Nom	M Nom	N Nom	P Nom	R Nom	Color Code (Ref.)	Inst. Tool Die No. (Note 2)
06	.312 (7.9)	.090 (2.3)	.113 (2.9)	.250 (6.4)	.156 (4.0)	.194 (4.9)	Yellow	WT402
10	.312 (7.9)	.124 (3.1)	.145 (3.7)	.250 (6.4)	.187 (4.7)	.227 (5.8)	Orange	WT406
13	.312 (7.9)	.149 (3.8)	.179 (4.5)	.250 (6.4)	.225 (5.7)	.256 (6.5)	Purple	WT409
16	.312 (7.9)	.175 (4.4)	.215 (5.5)	.250 (6.4)	.261 (6.6)	.297 (7.5)	Yellow	WT411
20	.312 (7.9)	.219 (5.6)	.250 (6.4)	.250 (6.4)	.297 (7.5)	.335 (8.5)	Green	WT414
23	.312 (7.9)	.250 (6.4)	.281 (7.1)	.250 (6.4)	.327 (8.3)	.372 (9.4)	Tin	WT416
26	.312 (7.9)	.275 (7.0)	.306 (7.8)	.250 (6.4)	.375 (9.5)	.406 (10.3)	Yellow	WT440/5451
29	.312 (7.9)	.297 (7.5)	.335 (8.5)	.250 (6.4)	.405 (10.3)	.453 (11.5)	Red	WT440/5452
30	.312 (7.9)	.312 (7.9)	.365 (9.3)	.250 (6.4)	.425 (10.8)	.473 (12.0)	Tin	WT440/5454
31	.312 (7.9)	.375 (9.5)	.406 (10.3)	.250 (6.4)	.500 (12.7)	.560 (14.2)	Green	WT440/5457
32	.600 (15.2)	.430 (10.9)	.500 (12.7)	.440 (11.2)	.590 (15.0)	.670 (17.0)	Red	GS590
33	.600 (15.2)	.550 (14.0)	.620 (15.7)	.440 (11.2)	.710 (18.0)	.790 (20.1)	Blue	GS710
34	.600 (15.2)	.670 (17.0)	.750 (19.1)	.440 (11.2)	.840 (21.3)	.920 (23.4)	Gray	GS840
35	.600 (15.2)	.810 (20.6)	.880 (22.4)	.440 (11.2)	1.010 (25.7)	1.090 (27.7)	Brown	GS1010
36	.600 (15.2)	.920 (23.4)	1.000 (25.4)	.440 (11.2)	1.130 (28.7)	1.210 (30.7)	Green	GS1130
38	.600 (15.2)	1.040 (26.4)	1.120 (28.4)	.440 (11.2)	1.250 (31.8)	1.330 (33.8)	Pink	GS1250
39	.600 (15.2)	1.122 (28.5)	1.192 (30.3)	.440 (11.2)	1.332 (33.8)	1.412 (35.9)	Orange	GS1332
40	.600 (15.2)	1.224 (31.1)	1.294 (32.9)	.440 (11.2)	1.440 (36.6)	1.520 (38.6)	Purple	GS1440
41	.600 (15.2)	1.353 (34.4)	1.423 (36.1)	.440 (11.2)	1.562 (39.7)	1.643 (41.7)	Yellow	GS1563
42	.600 (15.2)	1.425 (36.2)	1.545 (39.2)	.440 (11.2)	1.670 (42.4)	1.750 (44.5)	Red	GS1670
43	.600 (15.2)	1.550 (39.4)	1.670 (42.4)	.440 (11.2)	1.795 (45.6)	1.875 (47.6)	Blue	GS1795
44	.600 (15.2)	1.675 (42.5)	1.795 (45.6)	.440 (11.2)	1.920 (48.8)	2.000 (50.8)	Gray	GS1920
45	.600 (15.2)	1.800 (45.7)	1.920 (48.8)	.440 (11.2)	2.045 (51.9)	2.125 (54.0)	Brown	GS2045
46	.600 (15.2)	1.925 (48.9)	2.045 (51.9)	.440 (11.2)	2.170 (55.1)	2.250 (57.2)	Green	GS2170
47	.600 (15.2)	2.050 (52.1)	2.170 (55.1)	.440 (11.2)	2.295 (58.3)	2.375 (60.3)	Pink	GS2295
48	.600 (15.2)	2.175 (55.2)	2.295 (58.3)	.440 (11.2)	2.420 (61.5)	2.500 (63.5)	Orange	GS2420
49	.600 (15.2)	2.300 (58.4)	2.420 (61.5)	.440 (11.2)	2.545 (64.6)	2.625 (66.7)	Purple	GS2545
50	.600 (15.2)	2.425 (61.6)	2.545 (64.6)	.440 (11.2)	2.670 (67.8)	2.750 (69.9)	Yellow	GS2670
51	.600 (15.2)	2.530 (64.3)	2.670 (67.8)	.440 (11.2)	2.795 (71.0)	2.875 (73.0)	Red	GS2795
52	.600 (15.2)	2.655 (67.4)	2.795 (71.0)	.440 (11.2)	2.920 (74.2)	3.000 (76.2)	Blue	GS2920
53	.600 (15.2)	2.780 (70.6)	2.920 (74.2)	.440 (11.2)	3.045 (77.3)	3.125 (79.4)	Gray	GS3045
54	.600 (15.2)	2.905 (73.8)	3.045 (77.3)	.440 (11.2)	3.170 (80.5)	3.250 (82.6)	Brown	GS3170