

**CONNECTOR
DESIGNATORS
A-F-H-L-S
SELF-LOCKING
ROTATABLE
COUPLING**

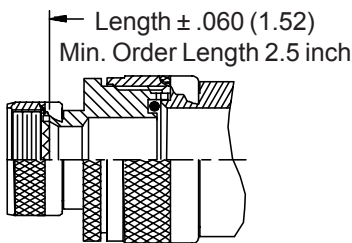

**STYLE 2
(STRAIGHT
See Note 1)**

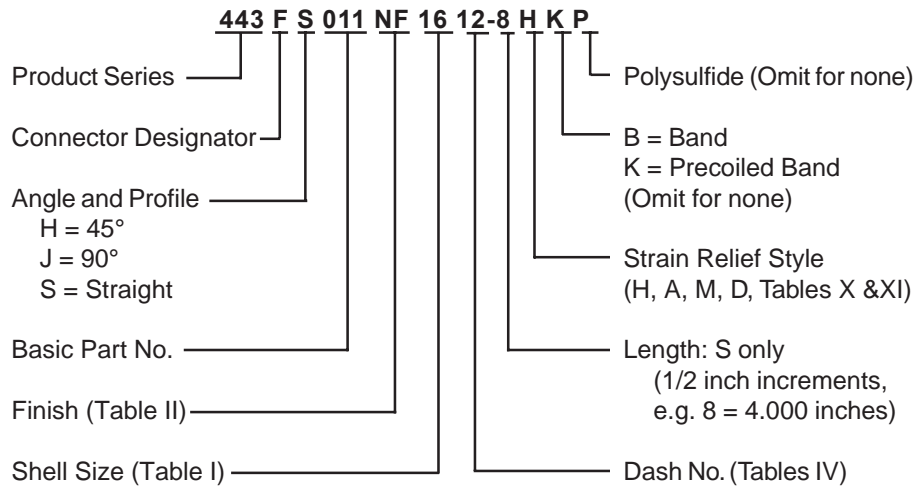
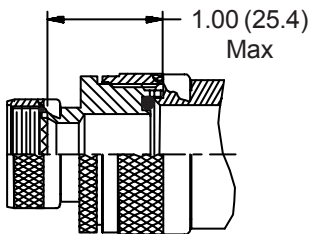
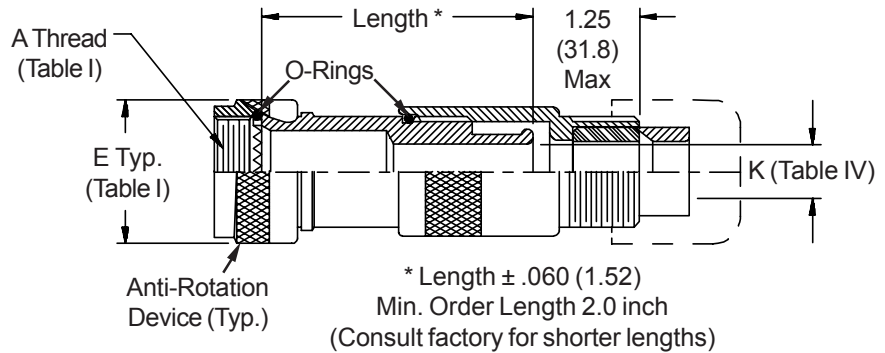

**STYLE 2
(45° & 90°
See Note 1)**

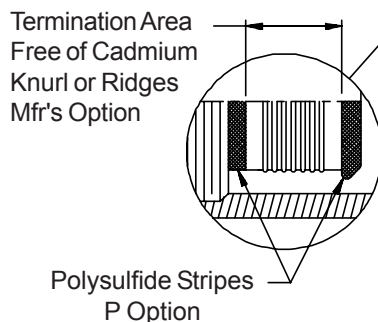
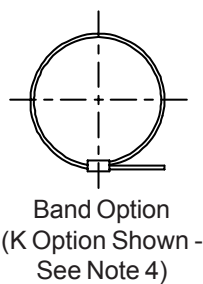
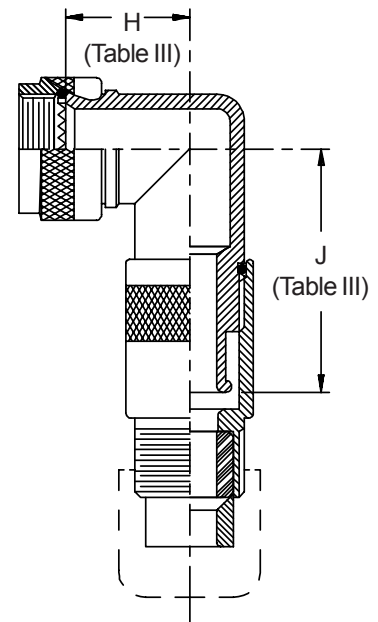
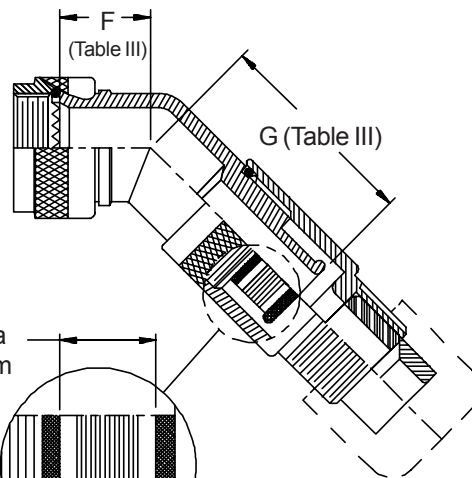

443-011
Submersible EMI/RFI Cable Sealing Backshell
Band-in-a-Can with Strain-Relief
Self-Locking Rotatable Coupling - Standard Profile



See inside back cover fold-out or pages 13 and 14 for Tables I and II.

TABLE III: ELBOW DIMENSIONS

| Shell Size | | F | G | H | J |
|--------------|-----------|-------------|--------------|--------------|--------------|
| Conn. Desig. | A-F-L-S H | Max | Max | Max | Max |
| 08 | 09 | .795 (20.2) | 1.380 (35.1) | .906 (23.0) | 1.500 (38.1) |
| 10 | 11 | .820 (20.8) | 1.410 (35.8) | .966 (24.5) | 1.550 (39.4) |
| 12 | 13 | .844 (21.4) | 1.430 (36.3) | 1.026 (26.1) | 1.610 (40.9) |
| 14 | 15 | .861 (21.9) | 1.460 (37.1) | 1.076 (27.3) | 1.680 (42.7) |
| 16 | 17 | .888 (22.6) | 1.480 (37.6) | 1.136 (28.9) | 1.740 (44.2) |
| 18 | 19 | .904 (23.0) | 1.490 (37.8) | 1.176 (29.9) | 1.760 (44.7) |
| 20 | 21 | .929 (23.6) | 1.510 (38.4) | 1.236 (31.4) | 1.820 (46.2) |
| 22 | 23 | .956 (24.3) | 1.550 (39.4) | 1.296 (32.9) | 1.900 (48.3) |
| 24 | 25 | .979 (24.9) | 1.580 (40.1) | 1.356 (34.4) | 1.970 (50.0) |

TABLE IV: CABLE ENTRY

| Dash No. | Clamp Size | K Dia |
|----------|------------|--------------|
| 02 | 03 | .125 (3.2) |
| 03 | 03 | .188 (4.8) |
| 04 | 03 | .250 (6.4) |
| 05 | 04 | .312 (7.9) |
| 06 | 06 | .375 (9.5) |
| 07 | 06 | .438 (11.1) |
| 08 | 08 | .500 (12.7) |
| 09 | 10 | .562 (14.3) |
| 10 | 10 | .625 (15.9) |
| 11 | 12 | .688 (17.5) |
| 12 | 12 | .750 (19.1) |
| 13 | 16 | .812 (20.6) |
| 14 | 16 | .875 (22.2) |
| 15 | 16 | .938 (23.8) |
| 16 | 20 | 1.000 (25.4) |
| 17 | 20 | 1.062 (27.0) |
| 18 | 20 | 1.125 (28.6) |
| 20 | 20 | 1.250 (31.8) |
| 22 | 24 | 1.375 (34.9) |
| 24 | 28 | 1.500 (38.1) |

TABLE X: CABLE ENTRY

| Clamp Size | T Max | V Max | Cable Range | |
|------------|--------------|--------------|--------------|--------------|
| | | | Min | Max |
| 04 | .780 (19.8) | .957 (24.3) | .125 (3.2) | .312 (7.9) |
| 06 | .780 (19.8) | 1.145 (29.1) | .250 (6.4) | .437 (11.1) |
| 08 | .780 (19.8) | 1.332 (33.8) | .387 (9.8) | .562 (14.3) |
| 10 | .780 (19.8) | 1.332 (33.8) | .350 (8.9) | .625 (15.9) |
| 12 | .811 (20.6) | 1.551 (39.4) | .500 (12.7) | .750 (19.1) |
| 16 | .905 (23.0) | 1.770 (45.0) | .625 (15.9) | .937 (23.8) |
| 20 | 1.092 (27.7) | 2.113 (53.7) | .875 (22.2) | 1.250 (31.8) |
| 24 | 1.124 (28.5) | 2.363 (60.0) | 1.000 (25.4) | 1.375 (34.9) |
| 28 | 1.399 (35.5) | 2.770 (70.4) | 1.250 (31.8) | 1.625 (41.3) |

TABLE XI: CABLE ENTRY

| Clamp Size | W Max | X Max | Y Max | Z Max | Cable Range | |
|------------|--------------|--------------|--------------|--------------|--------------|--------------|
| | | | | | Min ** | Max |
| 03* | .437 (11.1) | .760 (19.3) | .843 (21.4) | .630 (16.0) | .156 (4.0) | .250 (6.4) |
| 04* | .437 (11.1) | .760 (19.3) | .906 (23.0) | .755 (19.2) | .188 (4.8) | .312 (7.9) |
| 06* | .500 (12.7) | .760 (19.3) | 1.093 (27.8) | .942 (23.9) | .281 (7.1) | .438 (11.1) |
| 08 | .563 (14.3) | .760 (19.3) | 1.187 (30.1) | 1.067 (27.1) | .387 (9.8) | .562 (14.3) |
| 10 | .563 (14.3) | .760 (19.3) | 1.281 (32.5) | 1.192 (30.3) | .375 (9.5) | .625 (15.9) |
| 12 | .563 (14.3) | .760 (19.3) | 1.500 (38.1) | 1.380 (35.1) | .438 (11.1) | .750 (19.1) |
| 16 | .656 (16.7) | 1.073 (27.3) | 1.719 (43.7) | 1.535 (39.0) | .625 (15.9) | .938 (23.8) |
| 20 | .656 (16.7) | 1.323 (33.6) | 2.062 (52.4) | 1.848 (46.9) | .875 (22.2) | 1.250 (31.8) |
| 24 | .656 (16.7) | 1.323 (33.6) | 2.312 (58.7) | 2.255 (57.3) | 1.000 (25.4) | 1.375 (34.9) |
| 28 | 1.188 (30.2) | 1.572 (39.9) | 2.719 (69.1) | 2.505 (63.6) | 1.250 (31.8) | 1.625 (41.3) |

* Not available in Style M clamp. ** Not Applicable Style D

1. When maximum cable entry (page 21) is exceeded, Style 2 will be supplied. Dimensions F, G, H and J will not apply. Please consult factory.
2. O-Ring not supplied with Connector Designator A.
3. Backshells supplied with 600-052-* band, see Glenair Series 600 Tool Catalog for installation.

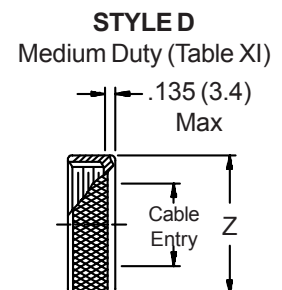
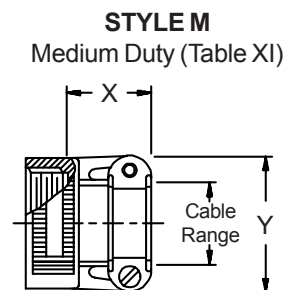
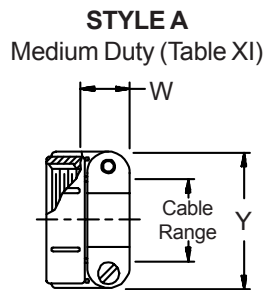
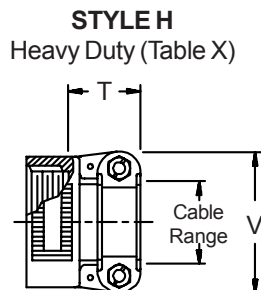

CONNECTOR DESIGNATORS
A-F-H-L-S
SELF-LOCKING ROTATABLE COUPLING

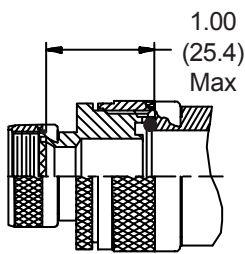
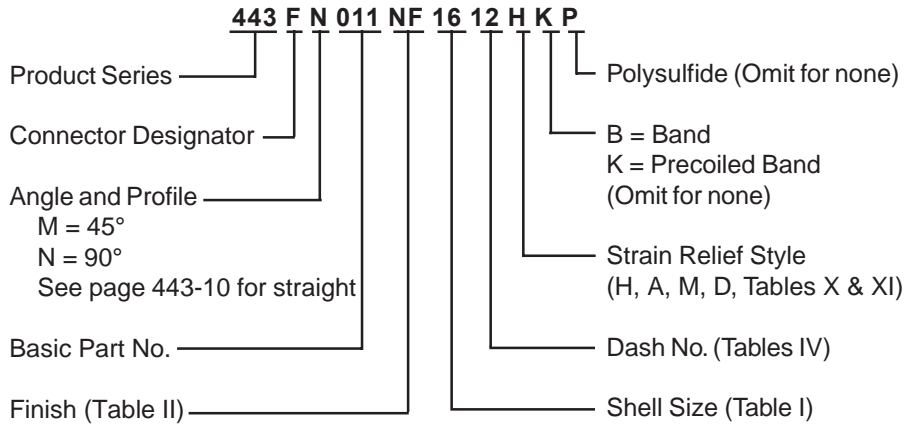

STYLE 2
(See Note 1)

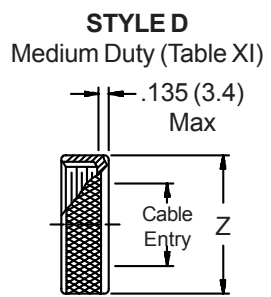
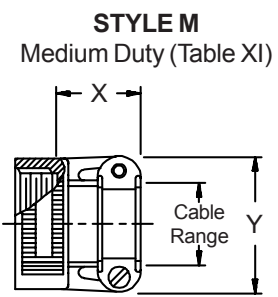
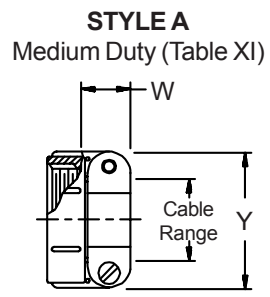
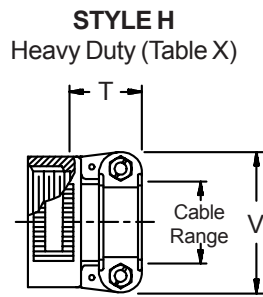
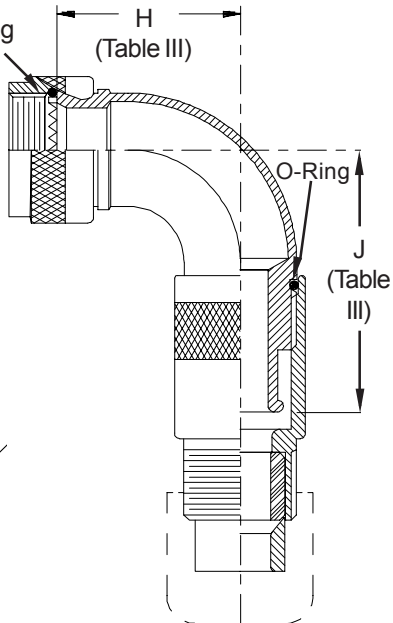
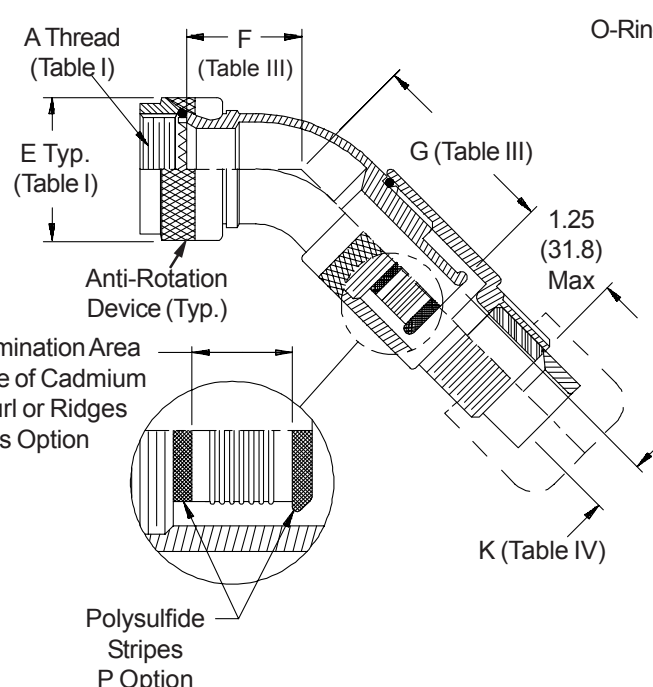
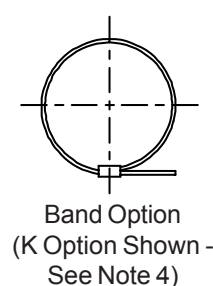

443-011
Submersible EMI/RFI Cable Sealing Backshell
Band-in-a-Can with Strain-Relief
Self-Locking Rotatable Coupling - Full Radius Profile



See inside back cover fold-out or pages 13 and 14 for Tables I and II.

| Shell Size | | F | | G | | H | | J | |
|--------------|----|-------|--------|-------|--------|-------|--------|-------|--------|
| Conn. Desig. | | Max | | Max | | Max | | Max | |
| A-F-L-S | H | | | | | | | | |
| 08 | 09 | .968 | (24.6) | 1.057 | (26.8) | 1.281 | (32.5) | 1.375 | (34.9) |
| 10 | 11 | 1.031 | (26.2) | 1.111 | (28.2) | 1.406 | (35.7) | 1.500 | (38.1) |
| 12 | 13 | 1.094 | (27.8) | 1.161 | (29.5) | 1.531 | (38.9) | 1.625 | (41.3) |
| 14 | 15 | 1.156 | (29.4) | 1.215 | (30.9) | 1.656 | (42.1) | 1.750 | (44.5) |
| 16 | 17 | 1.219 | (31.0) | 1.264 | (32.1) | 1.781 | (45.2) | 1.875 | (47.6) |
| 18 | 19 | 1.250 | (31.8) | 1.314 | (33.4) | 1.906 | (48.4) | 2.000 | (50.8) |
| 20 | 21 | 1.312 | (33.3) | 1.368 | (34.7) | 2.031 | (51.6) | 2.125 | (54.0) |
| 22 | 23 | 1.344 | (34.1) | 1.422 | (36.1) | 2.156 | (54.8) | 2.250 | (57.2) |
| 24 | 25 | 1.406 | (35.7) | 1.471 | (37.4) | 2.281 | (57.9) | 2.375 | (60.3) |

| Dash No. | Clamp Size | K Dia | |
|----------|------------|-------|--------|
| 02 | 03 | .125 | (3.2) |
| 03 | 03 | .188 | (4.8) |
| 04 | 03 | .250 | (6.4) |
| 05 | 04 | .312 | (7.9) |
| 06 | 06 | .375 | (9.5) |
| 07 | 06 | .438 | (11.1) |
| 08 | 08 | .500 | (12.7) |
| 09 | 10 | .562 | (14.3) |
| 10 | 10 | .625 | (15.9) |
| 11 | 12 | .688 | (17.5) |
| 12 | 12 | .750 | (19.1) |
| 13 | 16 | .812 | (20.6) |
| 14 | 16 | .875 | (22.2) |
| 15 | 16 | .938 | (23.8) |
| 16 | 20 | 1.000 | (25.4) |
| 17 | 20 | 1.062 | (27.0) |
| 18 | 20 | 1.125 | (28.6) |
| 20 | 20 | 1.250 | (31.8) |
| 22 | 24 | 1.375 | (34.9) |
| 24 | 28 | 1.500 | (38.1) |

| Clamp Size | T Max | V Max | Cable Range | | | |
|------------|--------------|--------------|--------------|--------------|-----|--|
| | | | Min | | Max | |
| 04 | .780 (19.8) | .957 (24.3) | .125 (3.2) | .312 (7.9) | | |
| 06 | .780 (19.8) | 1.145 (29.1) | .250 (6.4) | .437 (11.1) | | |
| 08 | .780 (19.8) | 1.332 (33.8) | .387 (9.8) | .562 (14.3) | | |
| 10 | .780 (19.8) | 1.332 (33.8) | .350 (8.9) | .625 (15.9) | | |
| 12 | .811 (20.6) | 1.551 (39.4) | .500 (12.7) | .750 (19.1) | | |
| 16 | .905 (23.0) | 1.770 (45.0) | .625 (15.9) | .937 (23.8) | | |
| 20 | 1.092 (27.7) | 2.113 (53.7) | .875 (22.2) | 1.250 (31.8) | | |
| 24 | 1.124 (28.5) | 2.363 (60.0) | 1.000 (25.4) | 1.375 (34.9) | | |
| 28 | 1.399 (35.5) | 2.770 (70.4) | 1.250 (31.8) | 1.625 (41.3) | | |

| Clamp Size | W Max | X Max | Y Max | Z Max | Cable Range | | |
|------------|--------------|--------------|--------------|--------------|--------------|--------------|-----|
| | | | | | Min ** | | Max |
| 03* | .437 (11.1) | .760 (19.3) | .843 (21.4) | .630 (16.0) | .156 (4.0) | .250 (6.4) | |
| 04* | .437 (11.1) | .760 (19.3) | .906 (23.0) | .755 (19.2) | .188 (4.8) | .312 (7.9) | |
| 06* | .500 (12.7) | .760 (19.3) | 1.093 (27.8) | .942 (23.9) | .281 (7.1) | .438 (11.1) | |
| 08 | .563 (14.3) | .760 (19.3) | 1.187 (30.1) | 1.067 (27.1) | .387 (9.8) | .562 (14.3) | |
| 10 | .563 (14.3) | .760 (19.3) | 1.281 (32.5) | 1.192 (30.3) | .375 (9.5) | .625 (15.9) | |
| 12 | .563 (14.3) | .760 (19.3) | 1.500 (38.1) | 1.380 (35.1) | .438 (11.1) | .750 (19.1) | |
| 16 | .656 (16.7) | 1.073 (27.3) | 1.719 (43.7) | 1.535 (39.0) | .625 (15.9) | .938 (23.8) | |
| 20 | .656 (16.7) | 1.323 (33.6) | 2.062 (52.4) | 1.848 (46.9) | .875 (22.2) | 1.250 (31.8) | |
| 24 | .656 (16.7) | 1.323 (33.6) | 2.312 (58.7) | 2.255 (57.3) | 1.000 (25.4) | 1.375 (34.9) | |
| 28 | 1.188 (30.2) | 1.572 (39.9) | 2.719 (69.1) | 2.505 (63.6) | 1.250 (31.8) | 1.625 (41.3) | |

* Not available in Style M clamp. ** Not Applicable Style D

1. When maximum cable entry (page 21) is exceeded, Style 2 will be supplied. Dimensions F, G, H and J will not apply. Please consult factory.
2. Metric dimensions (mm) are indicated in parentheses.
3. O-Ring not supplied with Connector Designator A.
4. Backshells supplied with 600-052-* band, see Glenair Series 600 Tool Catalog for installation.