

CONNECTOR DESIGNATORS
A-F-H-L

ROTATABLE COUPLING

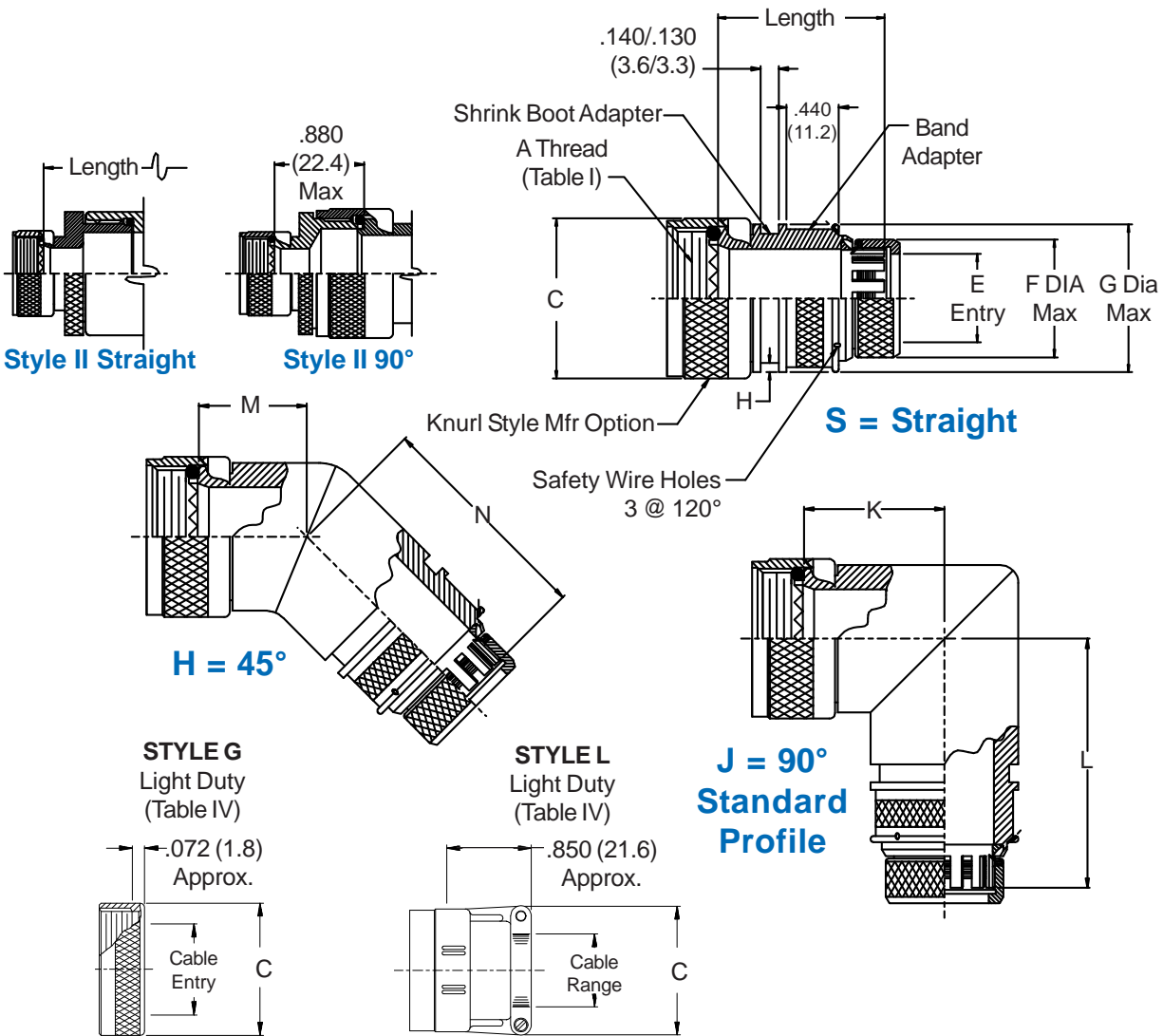

407-016
TAG® Ring Backshell
 with EMI/RFI Shield Termination Band & Shrink Boot Adapter
 Rotatable Coupling - Standard Profile

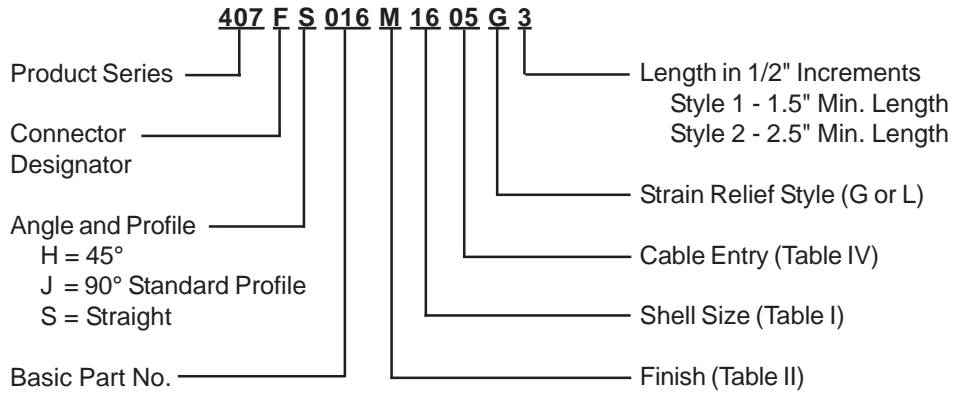

See inside back cover
 fold-out or pages 13 and
 14 for Tables I and II.

TABLE III: ELBOW DIMENSIONS

Shell Size		K Max	L Max	M Max	N Max	Max Entry Code A	Max Entry Code F, L & H
Conn. Desig. A-F-L	H						
08	09	.906 (23.0)	2.350 (59.7)	.795 (20.2)	2.240 (56.9)	02	02
10	11	.966 (24.5)	2.410 (61.2)	.820 (20.8)	2.270 (57.7)	03	03
12	13	1.026 (26.1)	2.470 (62.7)	.844 (21.4)	2.290 (58.2)	04	04
14	15	1.076 (27.3)	2.540 (64.5)	.861 (21.9)	2.320 (58.9)	05	05
16	17	1.136 (28.9)	2.600 (66.0)	.888 (22.6)	2.340 (59.4)	06	06
18	19	1.176 (29.9)	2.620 (66.5)	.904 (23.0)	2.350 (59.7)	06	07
20	21	1.236 (31.4)	2.680 (68.1)	.929 (23.6)	2.370 (60.2)	07	08
22	23	1.296 (32.9)	2.760 (70.1)	.956 (24.3)	2.410 (61.2)	08	09
24	25	1.356 (34.4)	2.830 (71.9)	.979 (24.9)	2.440 (62.0)	09	10

TABLE IV: CABLE ENTRY

Dash No.	E Entry	F Max	G Max	H Max	J Max	Cable Range	
						Min	Max
02	.250 (6.4)	.545 (13.8)	.650 (16.5)	.044 (1.1)	.968 (24.6)	.125 (3.2)	.250 (6.4)
03	.370 (9.4)	.670 (17.0)	.774 (19.7)	.044 (1.1)	1.046 (26.6)	.250 (6.4)	.375 (9.5)
04	.500 (12.7)	.795 (20.2)	.963 (24.5)	.044 (1.1)	1.156 (29.4)	.375 (9.5)	.500 (12.7)
05	.620 (15.7)	.920 (23.4)	1.042 (26.5)	.044 (1.1)	1.218 (30.9)	.500 (12.7)	.625 (15.9)
06	.750 (19.1)	1.045 (26.5)	1.217 (30.9)	.069 (1.8)	1.343 (34.1)	.625 (15.9)	.750 (19.1)
07	.870 (22.1)	1.170 (29.7)	1.355 (34.4)	.069 (1.8)	1.468 (37.3)	.750 (19.1)	.875 (22.2)
08	1.000 (25.4)	1.295 (32.9)	1.443 (36.7)	.069 (1.8)	1.593 (40.5)	.875 (22.2)	1.000 (25.4)
09	1.120 (28.4)	1.420 (36.1)	1.709 (43.4)	.069 (1.8)	1.718 (43.6)	.937 (23.8)	1.125 (28.6)
10	1.250 (31.8)	1.670 (42.4)	1.919 (48.7)	.069 (1.8)	1.843 (46.8)	1.062 (27.0)	1.250 (31.8)

1. Use with Glenair 600-052 bands and 600-058 standard or 600-067 pneumatic banding tools.
2. Metric dimensions (mm) are indicated in parentheses.
3. Cable range is defined as the accommodations range for the wire bundle or cable.
 Dimensions shown are not intended for inspection criteria.
4. When max entry code per Table III is exceeded, Style II will be supplied.
5. -445 modification not available for MIL-DTL-38999 Series II.

-445 Add "-445" to Specify Glenair's Non-Detent,
 ("NESTOR") Spring-Loaded, Self-Locking Coupling.
 See Page 41 for Details.