

**CONNECTOR
 DESIGNATORS
 A-F-H-L-S
 ROTATABLE
 COUPLING**

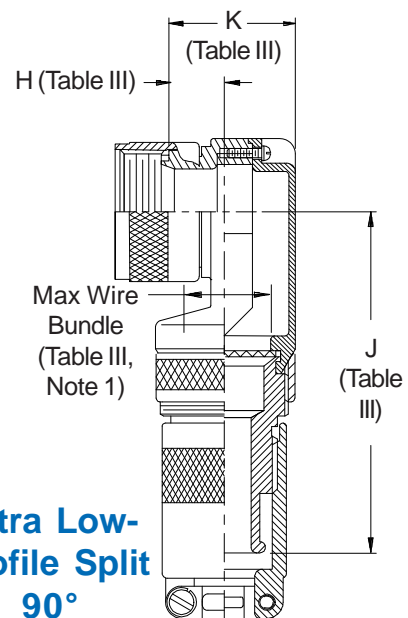
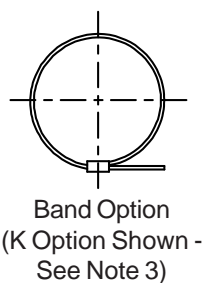
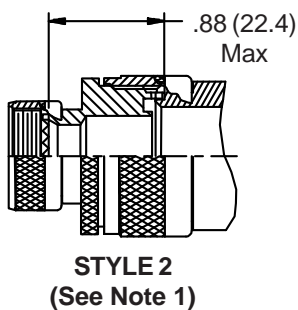
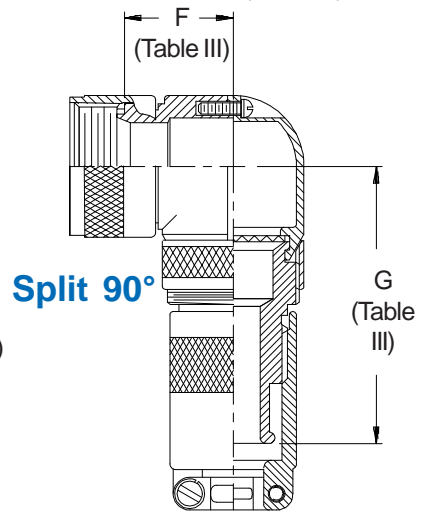
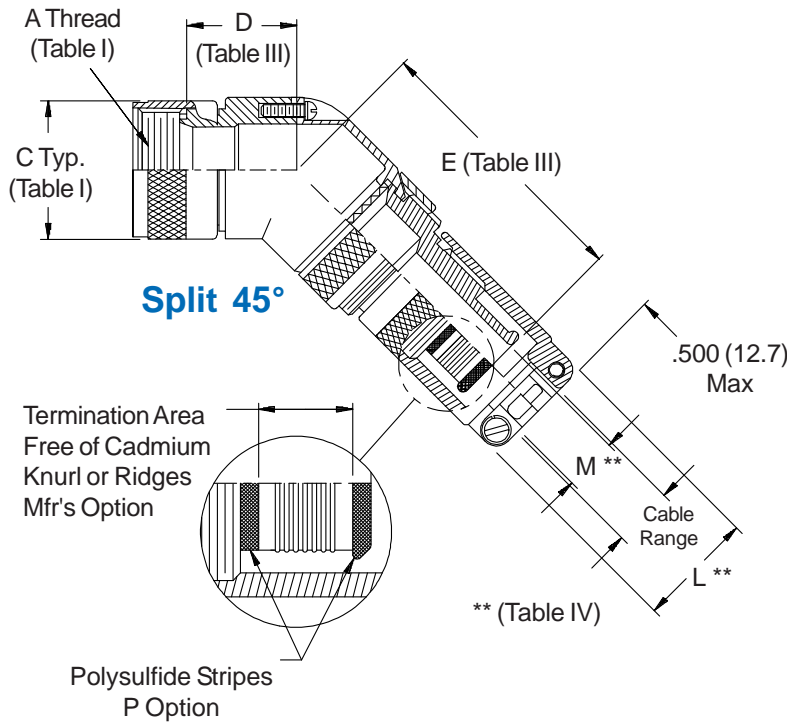
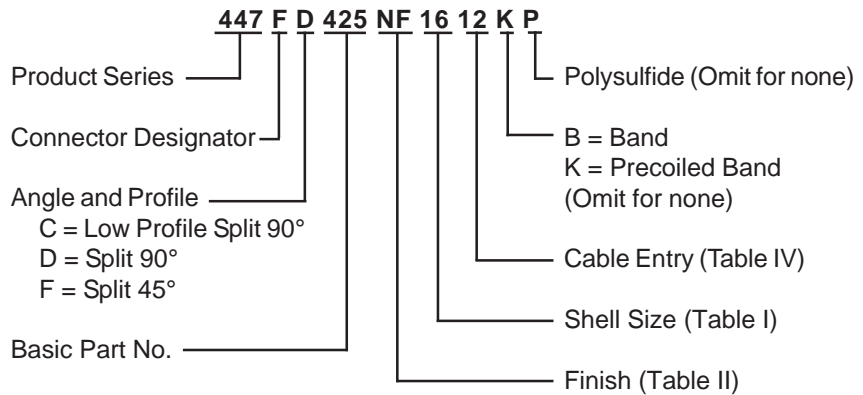

See inside back cover fold-out or pages 13 and 14 for Tables I and II.

TABLE III: ELBOW DIMENSIONS

Shell Size	D Max	E Max	F Max	G Max	H Ref	J Max	K Max	Function C Max Wire Bundle
08/09	.440 (11.2)	1.840 (46.7)	.680 (17.3)	1.780 (45.2)	.340 (8.6)	2.120 (53.8)	.681 (17.3)	.250 (6.4)
10/11	.500 (12.7)	1.900 (48.3)	.750 (19.1)	1.840 (46.7)	.270 (6.9)	2.280 (57.9)	.731 (18.6)	.375 (9.5)
12/13	.560 (14.2)	1.970 (50.0)	.810 (20.6)	1.910 (48.5)	.270 (6.9)	2.280 (57.9)	.731 (18.6)	.375 (9.5)
14/15	.620 (15.7)	2.000 (50.8)	.870 (22.1)	1.940 (49.3)	.280 (7.1)	2.350 (59.7)	.831 (21.1)	.500 (12.7)
16/17	.680 (17.3)	2.100 (53.3)	.930 (23.6)	2.040 (51.8)	.420 (10.7)	2.400 (61.0)	.981 (24.9)	.625 (15.9)
18/19	.750 (19.1)	2.160 (54.9)	1.000 (25.4)	2.100 (53.3)	.640 (16.3)	2.430 (61.7)	1.181 (30.0)	.625 (15.9)
20/21	.820 (20.8)	2.220 (56.4)	1.060 (26.9)	2.160 (54.9)	.640 (16.3)	2.430 (61.7)	1.181 (30.0)	.625 (15.9)
22/23	.880 (22.4)	2.280 (57.9)	1.120 (28.4)	2.220 (56.4)	.540 (13.7)	2.580 (65.5)	1.181 (30.0)	.750 (19.1)
24/25	.940 (23.9)	2.340 (59.4)	1.180 (30.0)	2.280 (57.9)	.540 (13.7)	2.580 (65.5)	1.181 (30.0)	.750 (19.1)

TABLE IV: CABLE ENTRY

Dash No.	K		L		Cable Range	
	±.030	±(.8)	Max		Min	Max
10	.220	(5.6)	1.000	(25.4)	.130	(3.3) .250 (6.4)
12	.310	(7.9)	1.250	(31.8)	.250	(6.4) .380 (9.7)
14	.440	(11.2)	1.340	(34.0)	.310	(7.9) .440 (11.2)
16	.560	(14.2)	1.470	(37.3)	.375	(9.5) .630 (16.0)
18	.630	(16.0)	1.560	(39.6)	.560	(14.2) .690 (17.5)
20	.750	(19.1)	1.620	(41.1)	.630	(16.0) .750 (19.1)
22	.880	(22.4)	1.750	(44.5)	.750	(19.1) .880 (22.4)
24	1.000	(25.4)	1.870	(47.5)	.880	(22.4) 1.000 (25.4)
28	1.060	(26.9)	1.970	(50.0)	1.000	(25.4) 1.130 (28.7)
32	1.190	(30.2)	2.090	(53.1)	1.130	(28.7) 1.250 (31.8)

1. When maximum cable entry (page 21) is exceeded, Style 2 will be supplied (not available in Function C). Dimensions D, E, F, and G will not apply. Please consult factory.
2. Metric dimensions (mm) are indicated in parentheses.
3. Backshells supplied with 600-052-* band, see Glenair Series 600 Tool Catalog for installation.
4. Angular function "C", low-profile split elbow, not available with "S" connector designator.