

507-011 NF 02 L 03 R

Basic Part No. _____
 Finish _____
 B = Cadmium Plate/Olive Drab
 M = Electroless Nickel
 N = Cadmium Plate/Olive Drab over Nickel Plate
 NF = Cadmium Olive Drab over Electroless Nickel (1000 Hour Salt Spray)

Dash No. (Table I) _____
 Entry Location _____

B = Back Entry
 F = Front Entry
 L = Left Side Entry
 R = Right Side Entry
 T = Top Entry

Entry Location Omit
 for only one entry
 B = Back Entry
 F = Front Entry
 L = Left Side Entry
 R = Right Side Entry
 T = Top Entry

Dash No. (Table I) Omit
 for only one entry

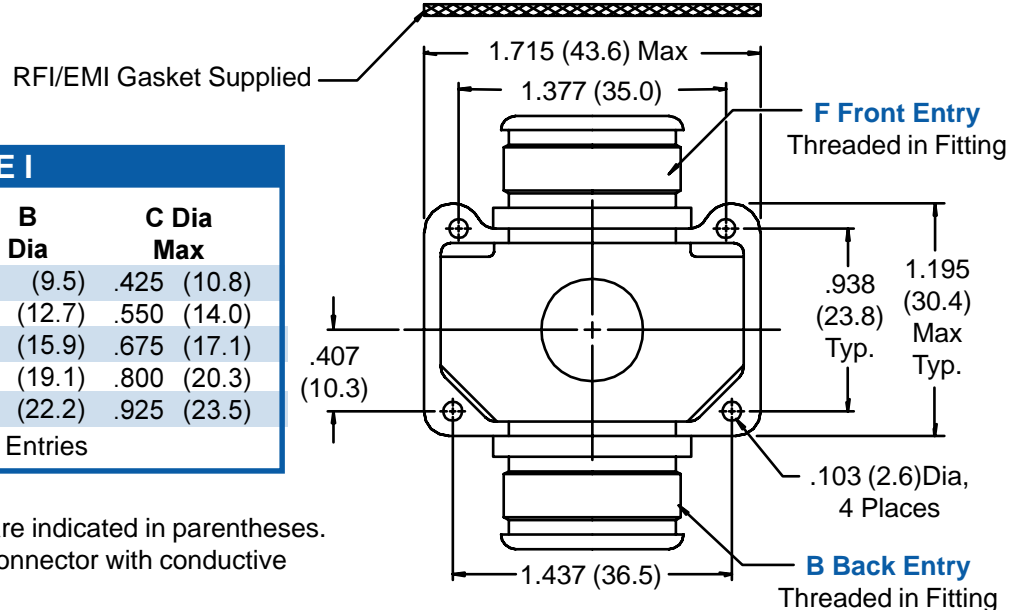
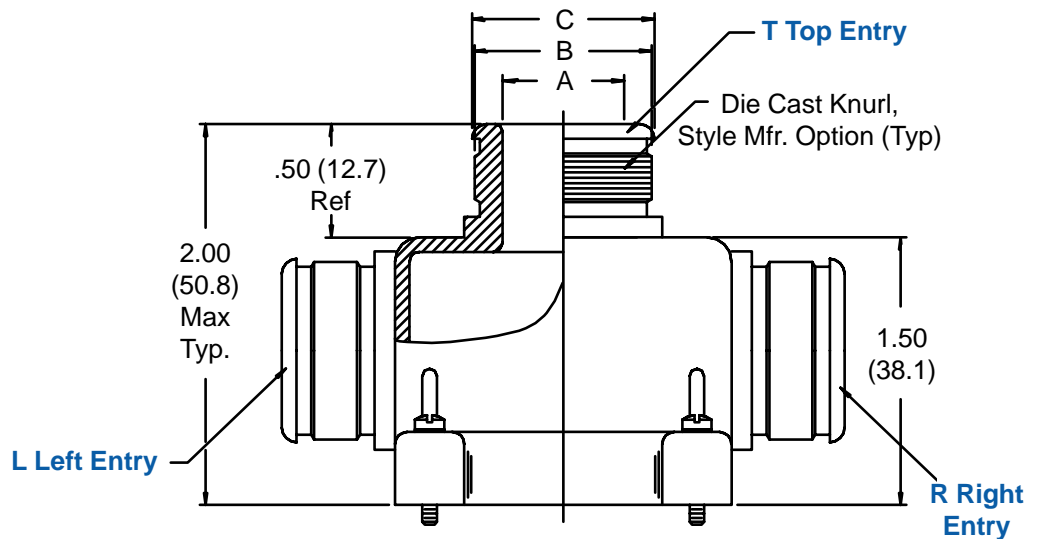

TABLE I

Dash No.	A Dia Min	B Dia	C Dia Max
01	.250 (6.4)	.375 (9.5)	.425 (10.8)
02	.375 (9.5)	.500 (12.7)	.550 (14.0)
03	.500 (12.7)	.625 (15.9)	.675 (17.1)
04*	.625 (15.9)	.750 (19.1)	.800 (20.3)
05*	.750 (19.1)	.875 (22.2)	.925 (23.5)

* Not Available in L and R Entries

1. Metric dimensions (mm) are indicated in parentheses.
2. For effective grounding, connector with conductive finish should be used.
3. Material/Finish:
 - Backshell = Al Alloy/Finish Per Option
 - Hardware = Cres/Passivate
 - Gasket = Monel and Neoprene