

220-06 and 220-16 Cable Connector Plug Assembly

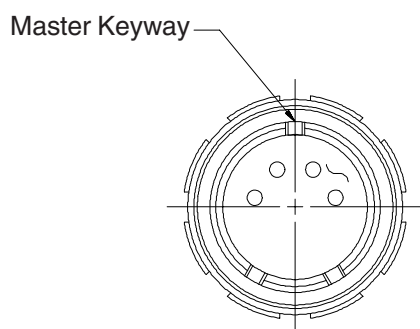

220-06: 1.19 (30.2) Max
220-16: 1.59 (40.4) Max

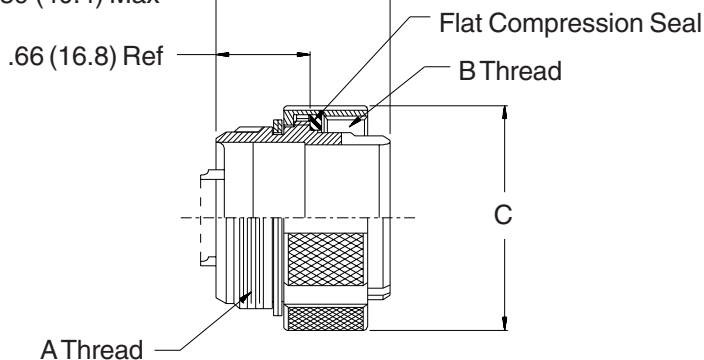

220-06 E 24-61 S N

Series No. _____
Shell Style _____
 06 = Standard
 16 = Scoop Proof
Class _____
 E = Environmental

_____ Polarization
 (N, 1, 2, 3, 4)
_____ P = Pins
 S = Sockets
_____ Insert Arrangement
_____ Shell Size

Metric dimensions (mm) are indicated in parentheses.

DIMENSIONS

| SHELL SIZE | A THREAD CLASS 2A | B THREAD CLASS 2B | C DIA MAX |
|------------|-------------------|-------------------|--------------|
| 10 | 5/8 - 24 UNEF | .750 - .1P - .1L | 1.000 (25.4) |
| 12 | 3/4 - 20 UNEF | .875 - .1P - .1L | 1.125 (28.6) |
| 14 | 7/8 - 20 UNEF | 1.000 - .1P - .1L | 1.250 (31.8) |
| 16 | 1 - 20 UNEF | 1.125 - .1P - .1L | 1.375 (34.9) |
| 18 | 1 1/8 - 16 UN | 1.250 - .1P - .1L | 1.594 (40.5) |
| 20 | 1 1/4 - 16 UN | 1.375 - .1P - .1L | 1.719 (43.7) |
| 22 | 1 3/8 - 16 UN | 1.500 - .1P - .1L | 1.894 (48.1) |
| 24 | 1 1/2 - 16 UN | 1.625 - .1P - .1L | 1.969 (50.0) |

RECOMMENDED COUPLING NUT ASSEMBLY TORQUE VALUES

| SHELL SIZE | INCH-POUNDS | | NEWTON-METERS | |
|------------|-------------|-----|---------------|-------|
| | MIN | MAX | MIN | MAX |
| 10 | 20 | 40 | 2.26 | 4.52 |
| 12 | 20 | 40 | 2.26 | 4.52 |
| 14 | 30 | 50 | 3.39 | 5.65 |
| 16 | 30 | 50 | 3.39 | 5.65 |
| 18 | 40 | 60 | 4.52 | 6.78 |
| 20 | 50 | 70 | 5.65 | 7.91 |
| 22 | 60 | 80 | 6.78 | 9.04 |
| 24 | 80 | 100 | 9.04 | 11.30 |

REPLACEMENT FLAT COMPRESSION SEAL

| SHELL SIZE | GLENAIR PART NO. |
|------------|------------------|
| 10 | G70653-10 |
| 12 | G70653-12 |
| 14 | G70653-14 |
| 16 | G70653-16 |
| 18 | G70653-18 |
| 20 | G70653-20 |
| 22 | G70653-22 |
| 24 | G70653-24 |