

THIS DRAWING IS UNPUBLISHED. RELEASED FOR PUBLICATION, 19
 © COPYRIGHT 19 BY AMP INCORPORATED, HARRISBURG, PA. ALL INTERNATIONAL RIGHTS RESERVED. AMP PRODUCTS MAY BE COVERED BY U.S. AND FOREIGN PATENTS AND/OR PATENTS PENDING.

LOC		DIST		P		F		REVISIONS		DATE	APPROVED
AF	50					ZONE	LTR	DESCRIPTION			
							M	ADDED -2 PER OG1A-0246-98	8/10/98	JR/JG	

SUGGESTED MATING TAB

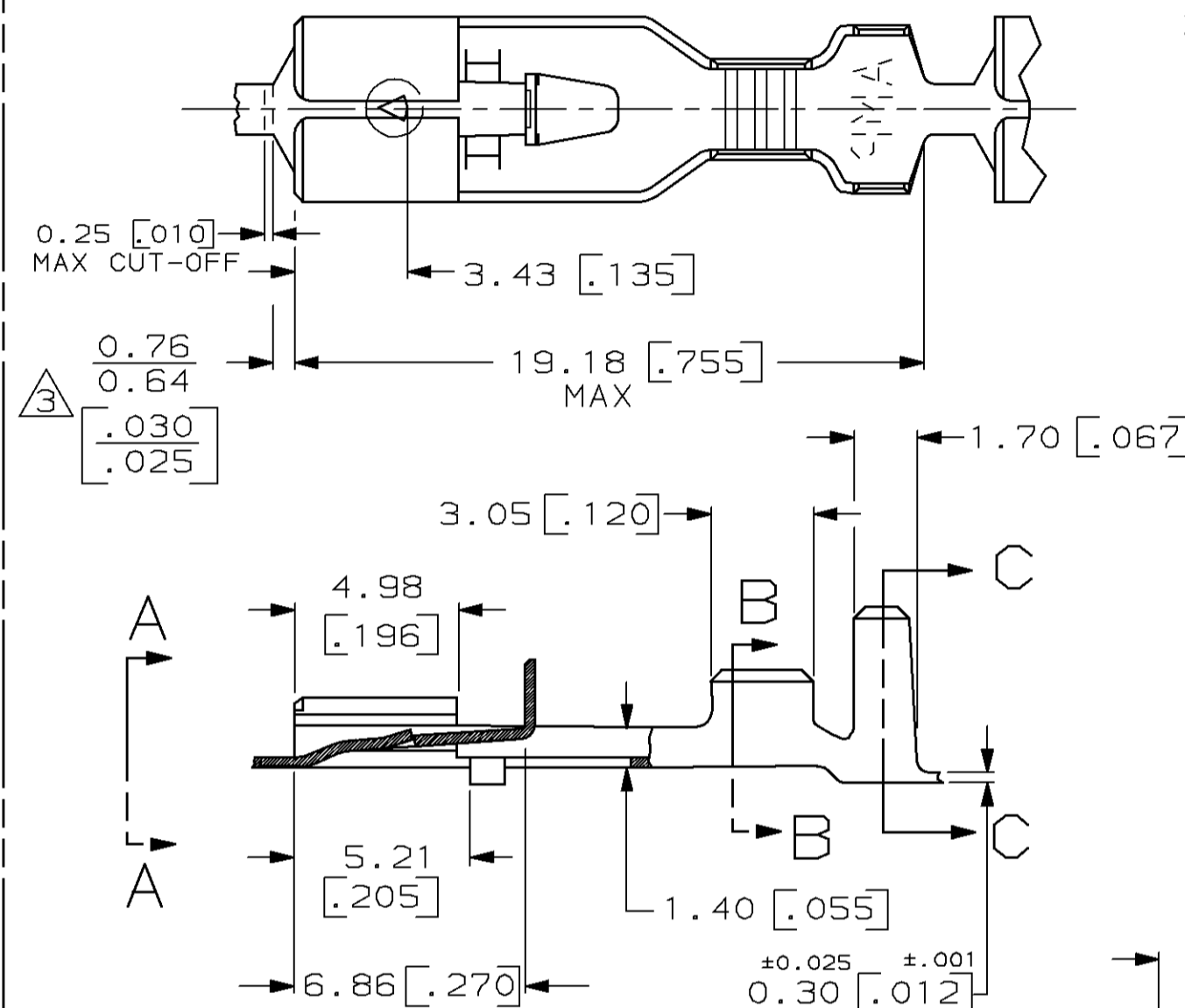
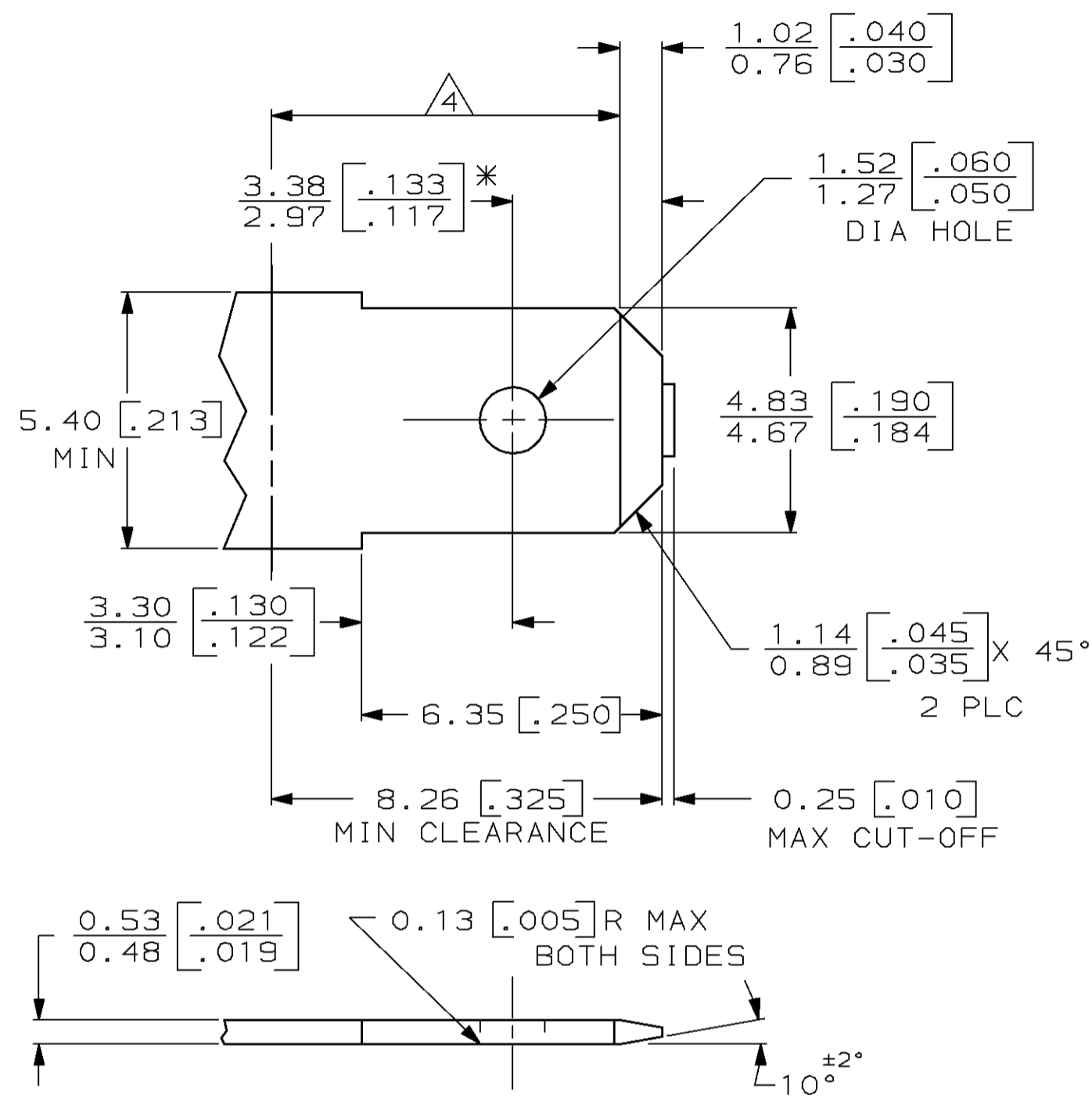

- 1 DIMENSIONS IN BRACKETS ARE IN INCHES.
- 2 CONTINUOUS STRIP ON REELS.
- △ THE 0.76 [.030] / 0.64 [.025] DIMENSION MUST BE MAINTAINED BY THE APPLICATOR CUT-OFF TO ENSURE THE PROPER LOCKING FUNCTION OF THE RECEPTACLE.
- 4 WIRE SIZES #20-#16, INSULATION RANGE IS 2.29-3.30 [.090-.130] DIA.

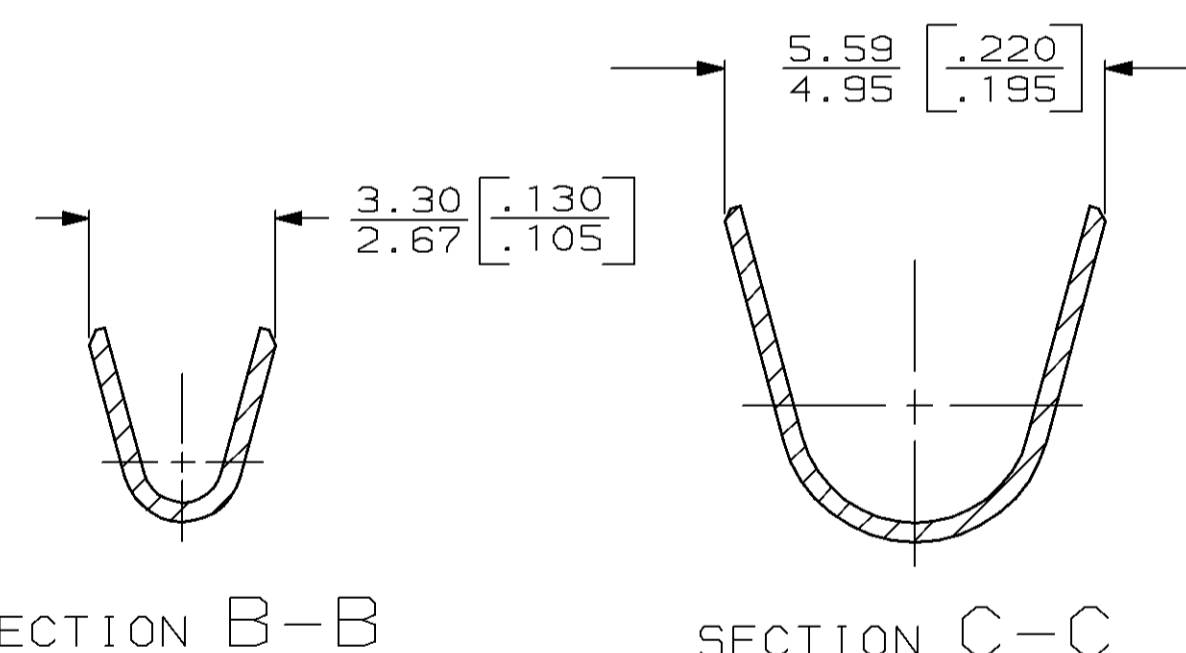
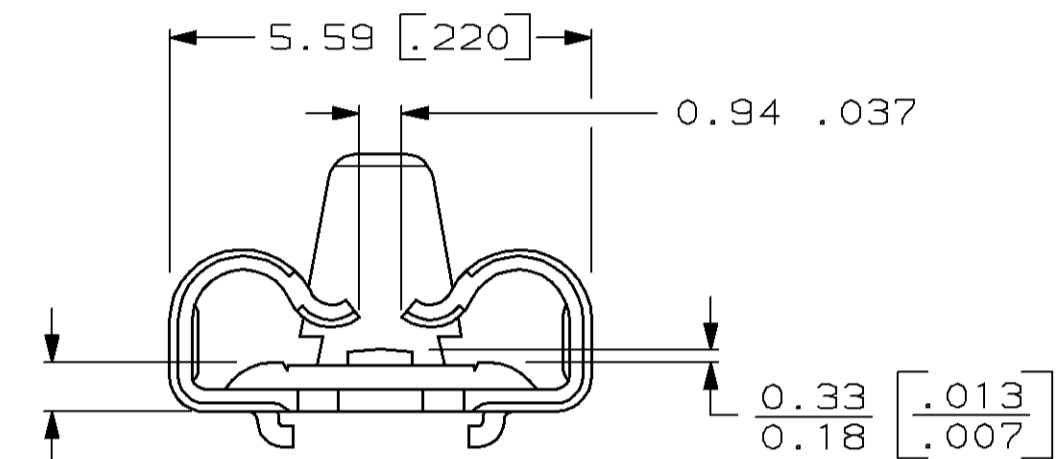

- 1 MATL: #2 HARD BRASS OR NICKEL PLATE STEEL.
 - 2 NO BURRS PERMISSIBLE AT HOLE.
 - 3 TIN PLATING IS REQUIRED ON BRASS WHEN TERMINAL TEMPERATURE IS OVER 225°F.
 - △ MUST BE FLAT WITHIN 0.076 [.003] OVER THIS LENGTH.
 - 5 HOLE MUST BE SYMMETRICAL ABOUT TAB \perp WITHIN 0.076 [.003].
- * TO BE USED ONLY WHEN SHOULDER IS ELIMINATED.

METRIC

UNLESS OTHERWISE SPECIFIED DIMENSIONS ARE IN MM TOLERANCES ON :	DR 2/28/87 JR RUTH
2 PL DEC ± -	CHK 3/9/87 G YETTER
3 PL DEC ± 0.25 [.010]	APPD 3/9/87 J GILLESPIE
ANGLES ± -	APPD 3/9/87 R KUZO
MATERIAL	#6H BRASS
FINISH	SEE TABLE
	PRODUCT SPEC -
	APPLICATION SPEC -
	WEIGHT -

-	63195-2
TIN	63195-1
FINISH	PART NO
AMP AMP INCORPORATED Harrisburg, Pa. 17105	
NAME RECEPTACLE, POSITIVE LOCK, .187 SERIES	
SIZE	FSCM NO
C	00779
DRAWING NO	63195
SCALE	NTS
SHEET	1 OF 1